



GENERATION 3

String Inverter Installation Manual

GIV-PV-3.6-G3 | GIV-PV-5.0-G3 | GIV-PV-6.0-G3

SPECIFICATIONS



GENERATION 3 String Inverter 3.6 | 5.0 | 6.0

Convert your solar panel output into usable energy for the home with the GivEnergy string inverter.

The string inverter will take the DC energy from your full solar array to a single source and convert it into usable AC for your home. When paired with a GivEnergy battery storage system, you'll also be able to save any excess generation and power your home on solar all day long.

Plus, with a max input current of 17A per string, and a max output power of 3.6kW – this string inverter is tough enough to supply the average home with ease.

SPECIFICATION

Dimensions

583H x 205D x 480W (mm)

Warranty

12 years

Weight

32Kg

Max. PV Voltage

600V

Operational Temperature

-25°C - +60°C

SKUs

GIV-HY-8.0-G3-HV

GIV-HY-10.0-G3-HV

Start Up Voltage

3.6kW - 90V

5.0kW - 90V

6.0kW - 90V

BOX CONTENTS

Item	Item Name	Qty
A	Inverter	1
B	Mounting Bracket Fixings	5
C	Mounting Bracket	1

A

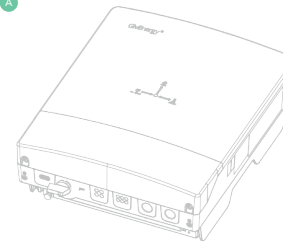

B

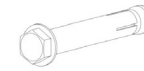

C

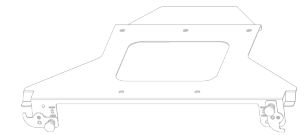

Introduction

All information contained in this booklet refers to the assembly, installation, commissioning, and maintenance of the Generation 3 String Inverter. Please retain this manual for future reference.

Legal Disclaimer: This document is the property of GivEnergy, reproduction is prohibited.

Installation Requirements

Installation of all GivEnergy equipment must be carried out by a **GivEnergy Approved Installer**.

Storing the Inverter

The unit must be stored in its original packaging at temperatures between 5°C - 60°C. Do not stack more than 4 units on top of each other.

Packaging Contents

When unpacking, please check the following:

- ✔ There are no missing accessories from the packaging list
- ✔ The model and specification of the inverter's nameplate match the order specifications

If any damaged or missing parts are found, please contact GivEnergy on **01377 252 874** or email **support@givenergy.co.uk** immediately. Returns must be provided in original or equivalent packaging. The cardboard packaging is recyclable.

Item	Item Name
A	Power Flow Direction Indicators
B	PV Input Switch
C	PV Input Terminals
D	LC, RS485, METER, LAN, CAN, DRM
E	WiFi or 3G / 4G Module (USB Port)
F	AC Supply Terminals
G	Machine Serial No.
H	WiFi Serial No. and Verification Code
I	Warning Signs Label
J	Specification Label

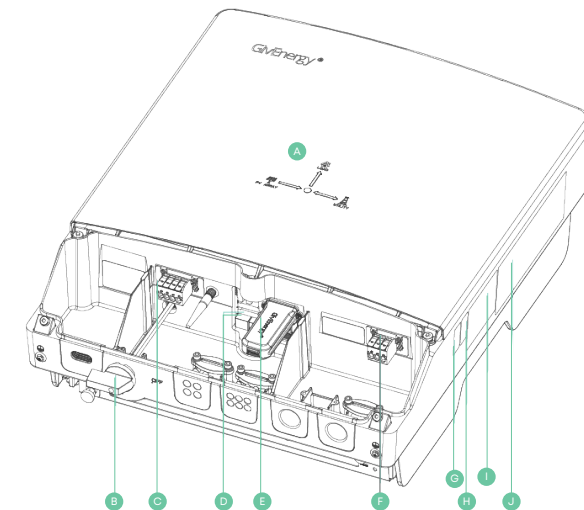

Safety Instructions

Extra care and attention must be taken when installing and maintaining any GivEnergy equipment. The system is capable of retaining a high voltage, even when disconnected.

- ✔ If you suspect something is wrong with the inverter, contact GivEnergy on **01377 252 874** or email **support@givenergy.co.uk**
- ✔ If there are any damaged or missing parts, please contact GivEnergy on **01377 252 874** or email **support@givenergy.co.uk** immediately. Returns must be provided in original or equivalent packaging.
- ✔ All electrical installations must be carried out by a qualified and registered Electrician and in accordance with the IEE Wiring Regulations
- ✔ During operation, the heat sink may become hot. Do not touch the heat sink at the sides, or the top of the inverter when in operation
- ✔ The inverter is designed to be connected to the grid; connecting your inverter to a generator or other power source can result in damage to the inverter or external devices
- ✔ All GivEnergy equipment must be installed by a GivEnergy Approved Installer



The inverter must be installed in an easily accessible location, the status display must be visible and not obstructed



Please ensure that the wall to be mounted on is sufficient enough to hold the weight of the inverter and battery pack



The inverter must be installed in a well ventilated area, the ambient temperature should be below 40°C to ensure optimal operation



The inverter must be installed vertically with connections always positioned at the bottom, never install horizontally, and avoid tilting the unit



The inverter must be installed under a canopy if installing externally. Avoid direct sunlight and near water sources



Mount the inverter at least 3 feet above ground level (outside only)

Precautions

- ✔ It is very important for system safety and efficient operation to use appropriate cables for battery connections. 16mm² (minimum) tri-rated cables must be used for DC battery connections
- ✔ The voltage of the battery connected must not exceed 60V (or it will damage the inverter and void any warranty)
- ✔ Only GivEnergy batteries should be connected to our inverters
- ✔ Reversed polarity will damage the inverter
- ✔ The inverter must be installed in accordance with the Inverter Installation Guide

STEP-BY-STEP INSTALLATION

Below is a list of the tools and equipment required to install the Gen 3 hybrid inverter

- | | | |
|------------------------|-----------------|---------------------------------------|
| ✔ Pencil | ✔ Wire Stripper | ✔ Safety Goggles |
| ✔ Electric Screwdriver | ✔ Multimeter | ✔ Flathead and Crosshead Screwdrivers |
| ✔ Allen Key | ✔ Spirit Level | ✔ Tape Measure |
| ✔ Impact Drill | ✔ Pliers | ✔ Crimping Pliers |

1. Wall thickness for mounting the inverter must be no less than 100mm. Place the wall mounting bracket horizontally onto the wall and mark the position of the bracket holes.

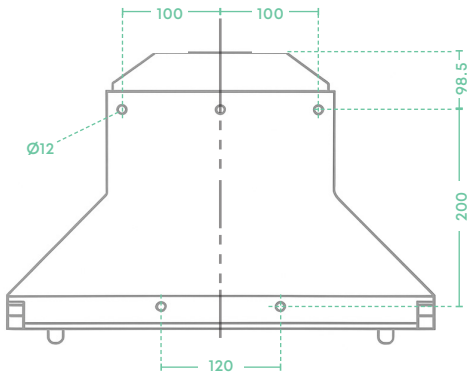

2. Drill 5 holes at the marked positions, at least 80mm deep. Fix the mounting bracket to the wall using 5 x M6x70 expansion bolts.

Please note: If fitting the inverter to a non-masonry wall, different fixings will be required.

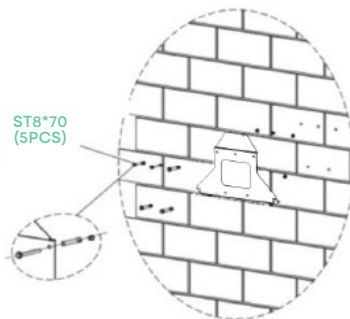

STEP-BY-STEP INSTALLATION

3. Mount the inverter onto the mounting bracket.

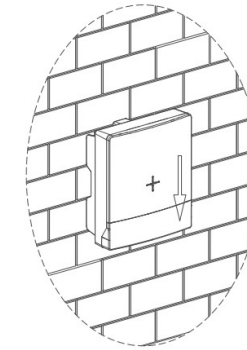

4. Insert the 2 x M4 safety locking screws on the left and right side to prevent the inverter from being lifted off the bracket.

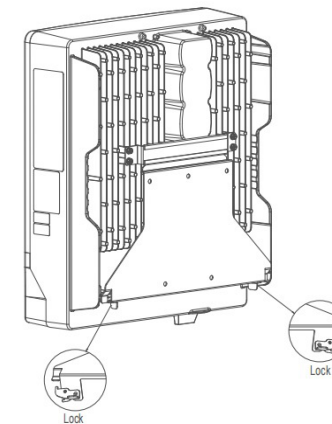

CLEARANCE AND MAINTENANCE

Space Clearance

There must be adequate clearance around the inverter to allow for heat dissipation. The diagram below illustrates the space required around the inverter.



Maintenance

When maintaining and cleaning the inverter, the **whole system must be powered down**. Please refrain from using cleaning products on the surface of the inverter.

To ensure your inverter operates optimally at all times, annual maintenance checks need to be carried out. Check for visible damage or discolouration of the switch, and that the cables are intact. Please ensure that the top of the inverter is not obstructed in any way.

We recommend operating the rotary isolator from ON to OFF 5 times, this cleans the contacts of the rotary switch.

CONNECTIONS OVERVIEW

Item	Item Name
A	2 Hexagon Socket Screws, M6x14
B	Wiring Chamber
C	Wire Sealing Ring
D	Fixed Wire
E	8 Internal Hexagonal Screws, M5x18
F	2 Phillips Screws, M4x8
G	Inverter Serial and WiFi Serial Number
H	Warning Signs Label
I	Specification Label
J	PV Input Switch
K	PV Input Terminals
L	Built In WiFi Antenna
M	Signal connection: CT, BMS, METER, LAN, CAN, DRM, PARALLEL
N	AC Supply Terminals
O	External WiFi or 4G Module (USB Port)

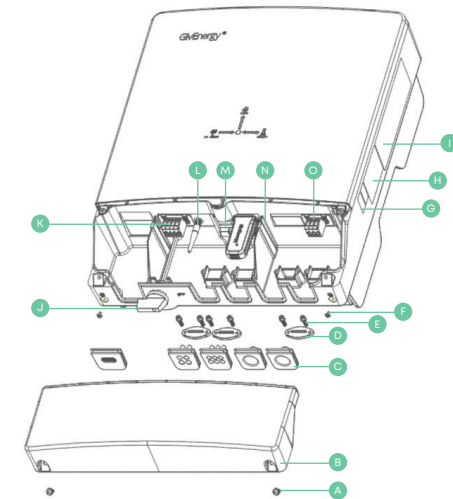

COMMUNICATION CONNECTIONS

Please ensure the system is turned off before modifying anything.

SW1



WiFi

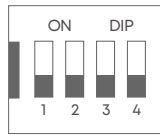

USB

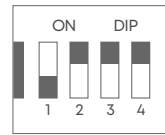

LAN

Item	Function	Foot Position	Note
E1	DI1 and DI2 Input Port	1: DI1+ 2: DI1- 3: DI2+ 4: DI2-	
E2	Meter and EMS communication Port	1: Meter-RS485+ 2: Meter-RS485- 3: GND 4: EMS-RS485+ 5: EMS-RS485-	
E3	CT and Reserve BMS Communication Port	1: Meter-RS485+ 2: Meter-RS485- 3: GND 4: EMS-RS485+ 5: EMS-RS485-	BMS communication method is CAN or RS485 based on E10 DIP switch
E4	DRM Port		
E5	LAN Port		
E6	DO1 and DO2 Output Port	1: DO1+ 2: DO1- 3: DO2+ 4: DO2-	
E7	Parallel Port		
E8	Parallel Port		

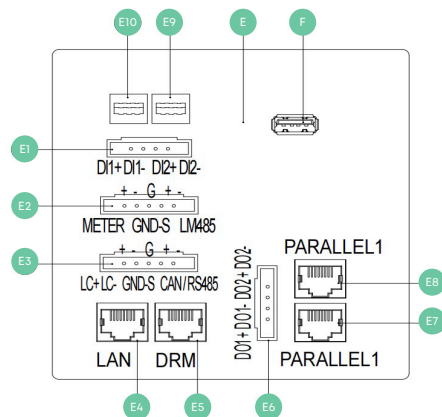

AC UTILITY GRID CONNECTION

Cable size requirements for the String Inverter are dependant on the model:

- ✓ **HY 8.0** - minimum 4mm² - 6.7mm²
- ✓ **HY 10.0** - minimum 2.5mm² - 8.4mm²

The recommended maximum cable length should not exceed 50m as the resistance of the cable will consume inverter output power and reduce the inverter efficiency.

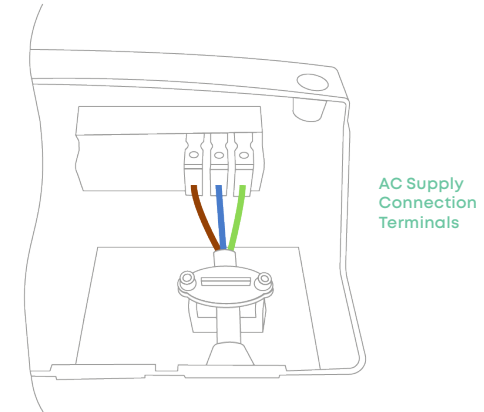

	Maximum Output	Overcurrent Protection	RCD Protection (if required)**	Minimum Cable size*
String Inverter 3.6kW	16A	C20	Type A 30mA	4mm
String Inverter 5.0kW	21.7A	C25 or C32		6mm
String Inverter 6.0kW	26A	C32		6mm

*This is the minimum size cable, large CSA may be required – Refer to BS7671
**See separate RCD declaration

CONNECTING MID APPROVED METER TO INVERTER

In the system, a mid approved meter must be installed to ensure correct monitoring of the grid power. The inverter uses this information to decide whether to charge or discharge the battery.

The CT clamp that is connected to the mid approved meter must be installed around the live incoming supply to the property, with the arrow pointing in the direction of grid import, in order to monitor the complete consumption of the building.

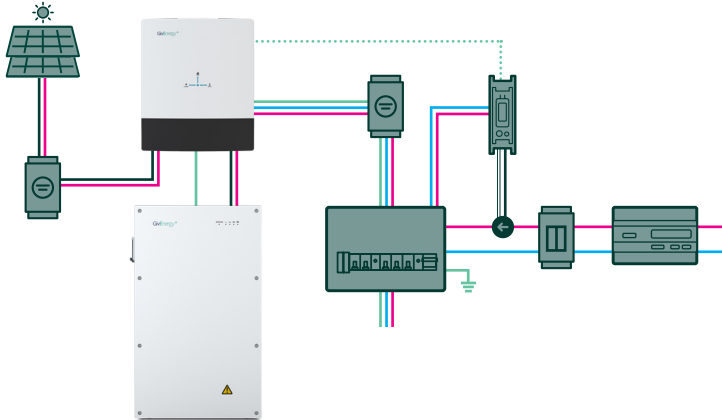

LABEL DESCRIPTION

Nameplate

This provides unique identification of the inverter (product type, device-specific characteristics, certificates and approvals). The nameplate is located on the right side of the inverter.

GivEnergy® PV Inverter	
Model	GIV-PV-6.0-G3
Input Data(PV)	
Max. PV Open-circuit Voltage	600Vd.c.
Max. PV Short-circuit Current	2+23Ad.c.
Max. PV Input Current	2+17Ad.c.
PV Input Voltage Range	90 – 600Vd.c.
MPPT Voltage Range	90 – 550Vd.c.
Number of MPP Trackers	2
Output Data(AC)	
Rated AC Output Power	6000W
Rated/Max. Apparent Power	6000VA
Nominal AC Voltage	230Va.c.
AC Grid Frequency	50Hz
Rated Output Current	26Aa.c.
Power Factor Range	0.8lagging-0.8leading
Others	
Inverter topology	Non-isolated
Overvoltage Category	AC III , DC II
Ingress Protection	IP65
Protective Class	Class I
Operating Temperature Range	-25~+60 °C
Serial Number:	

GivEnergy® PV Inverter	
Model	GIV-PV-5.0-G3
Input Data(PV)	
Max. PV Open-circuit Voltage	600Vd.c.
Max. PV Short-circuit Current	2+23Ad.c.
Max. PV Input Current	2+17Ad.c.
PV Input Voltage Range	90 – 600Vd.c.
MPPT Voltage Range	90 – 550Vd.c.
Number of MPP Trackers	2
Output Data(AC)	
Rated AC Output Power	5000W
Rated/Max. Apparent Power	5000VA
Nominal AC Voltage	230Va.c.
AC Grid Frequency	50Hz
Rated Output Current	21.7Aa.c.
Power Factor Range	0.8lagging-0.8leading
Others	
Inverter topology	Non-isolated
Overvoltage Category	AC III , DC II
Ingress Protection	IP65
Protective Class	Class I
Operating Temperature Range	-25~+60 °C
Serial Number:	

Warning Labels

Located under the nameplate of the inverter as shown in the picture:

CAUTION!
 Risk of electric shock. Each circuit must be individually disconnected and the service person must wait 5 minutes before servicing.

CAUTION!
 Risk of electric shock. Do not remove Cover. No user serviceable parts inside. Refer servicing to qualified service personnel.

CAUTION!
 Hot surface. Do not touch.

When the photovoltaic array is exposed to light, it supplies a DC voltage to the PCE.

Please look at the safety instructions within the device and also in the inverter manual.

Serial Number

Located on the right side of the inverter, the current inverter serial number information.

GIV: PV - 6.0 - G3

1 2

Number	Paraphrase	Instructions
1	Inverter Type	Photovoltaic Inverter
2	Rated Output Power	6.0: Rated Output Power 6.0kW

START-UP AND SHUT-DOWN OF THE INVERTER

Start-Up Procedure

1. Connect the AC circuit breaker, ensure that the system is powered and commissioned using the portal/App. Ensure that the grid power is reading identical to that of the mid approved meter (this can be found on the screen of the meter).
2. Turn on the DC switch.
3. The inverter will start automatically when the PV voltage is higher than 90V.

Shutdown Procedure

1. Disconnect the AC circuit breaker to prevent it from being reactivated.
2. Turn off the PV switch.
3. Check the inverter operating status.
4. Wait until all LEDs have gone out. The inverter is now shut down.

GROUNDING REQUIREMENTS

- ✔ Equipment to be grounded, when installing, must first install a protective ground wire; When removing equipment, the protective ground wire must be removed last
- ✔ The grounding of the energy storage inverter meets the local requirements for the grounding of photovoltaic modules and energy storage inverters. To ensure continuous conduction with the ground in order to optimally protect the system and personnel.

The system must not be operated without being grounded.

COMMISSIONING A SYSTEM

All systems must be commissioned to ensure correct battery and meter communications, as well as connection to the online portal.

Note: Without commissioning, the system may not operate correctly.

Check that all the wires are securely connected before the battery breaker and the AC isolator is switched on.

Accessing the Commissioning Portal

Sign into the online portal at <https://portal.givenergy.cloud> with your GivEnergy Engineer login. If you are a first time user, and you do not have an account or Engineer login, please consult your supplier to get this set up.

✔ To download a fully illustrated guide, please visit the Resource Hub on the GivEnergy website.

DECOMMISSIONING A SYSTEM

Uninstalling the Inverter

1. Follow the shut-down procedure.
2. Remove all connections and cables from the inverter.
3. Remove the locking pins which are securing the inverter to the bracket.
4. Lift the inverter off the bracket.
5. Remove the wall bracket.

Packaging the Inverter

If possible, always pack the inverter in its original packaging and secure it with tension belts. If this is not available, you may also use an equivalent sized box. The box must be capable of being closed completely and be strong enough to support both the weight and the size of the inverter.

Storing the Inverter

Store the inverter in a dry place where ambient temperatures are always between -25°C and +60°C.

MANUFACTURER WARRANTIES

This inverter is covered by a 12-year warranty.



String Inverter Gen 3 / 3.6 | 5.0 | 6.0
12-year warranty

GivEnergy

Phone

UK +44 01377 252 874
NL +31 85 208 6376

Email

UK support@givenergy.co.uk
NL support@givenergy.com
SA support.sa@givenergy.com
AU martin.cobb@givenergy.com

Website

www.givenergy.com