



SINGLE PHASE

# Hybrid Inverter Installation Manual

HY 8.0 | HY 10.0

## SPECIFICATIONS



### A TRUE MULTI-TASKER Battery and Solar Inverter in One

The third generation of the GivEnergy Hybrid Inverter is a battery and solar inverter in one unit.

It can be coupled directly with solar panels to generate electricity in the property during daylight hours, as well as store any excess energy for later use in our batteries to minimise export. Additionally, it will minimise import by discharging to meet demand in the property.

The Hybrid Inverter GEN 3 is connected to our batteries using an all-in-one plug, for an easier installation process.

#### SPECIFICATION

##### Dimensions

588H x 214D x 480W (mm)

##### Warranty

12 years

##### Weight

32Kg

##### Max. DC Input Power

12kW

##### Operational Temperature

-25°C - +60°C

##### SKUs

GIV-PV-3.6-G3

GIV-PV-5.0-G3

GIV-PV-6.0-G3

##### Start Up Voltage

8.0kW - 80V

10.0kW - 80V

#### System Sizing

- High Voltage (HV) inverters can operate with **3 to 24 battery packs**.
- The available DC battery power is approximately **2.2 kW per connected battery**. Therefore, the total power output depends on the number of battery packs used in your system.
- Batteries can be arranged in a **single stack of up to 6 packs**. You can also **parallel up to 4 stacks** of batteries to increase your system's capacity. For example, to achieve a 20 kW DC battery power output, you would need a minimum of 10 battery packs, arranged as two parallel stacks of 5 packs each.
- **If you plan to parallel battery stacks**, please inform your wholesale supplier that you require the **newer stackable battery kits**. These kits are specifically designed for parallel configurations and feature both "In" and "Out" battery connections, which are essential for proper system operation.
- **Always ensure you size the system to meet the customer's specific power requirements** by selecting the appropriate number of HV battery packs.
- Parallel battery operation is **supported on all HV inverters** - 8/10kW single phase, 11kw 3 phase & 15/20kw 3 phase.

## BOX CONTENTS

Item	Item Name	Qty
A	Inverter	1
B	Mounting Bracket Fixings	5
C	Mounting Bracket	1



## Introduction

All information contained in this booklet refers to the assembly, installation, commissioning, and maintenance of the Generation 3 Hybrid Inverter. Please retain this manual for future reference.

**Legal Disclaimer:** This document is the property of GivEnergy, reproduction is prohibited.

## Installation Requirements

Installation of all GivEnergy equipment must be carried out by a **GivEnergy Approved Installer**.

## Unit Information

The Hybrid Inverter is a battery and PV inverter in one. It is bi-directional, meaning it can charge from the grid (AC coupled) and from solar (DC coupled). The energy generated by photovoltaic systems is used to optimize self consumption. The excess energy is used to charge the battery and then fed into the public grid when the photovoltaic energy is sufficient.

When the photovoltaic energy output is insufficient to support the connected load, if the battery capacity is sufficient, the system will automatically obtain energy from the battery. If the battery capacity is insufficient to meet its own consumption needs, electricity will be extracted from the public grid.

## Storing the Inverter

The unit must be stored in its original packaging at temperatures between 5°C - 60°C. Do not stack more than 4 units on top of each other.

## Packaging Contents

When unpacking, please check the following:

- ✔ There are no missing accessories from the packaging list
- ✔ The model and specification of the inverter's nameplate match the order specifications

If any damaged or missing parts are found, please contact GivEnergy on **01377 252 874** or email **support@givenergy.co.uk** immediately. Returns must be provided in original or equivalent packaging. The cardboard packaging is recyclable.

Item	Item Name
A	Power Flow Direction Indicators
B	All in One Battery Connection
C	PV Isolator
D	PV Input Terminals
E	USB Port for 4G Module (Optional)
F	Meter Communications and LAN
G	EPS Terminals
H	AC Grid Supply
I	WiFi Serial No. and Verification Code
J	Warning Signs Label
K	Specification Label
L	Specification Label

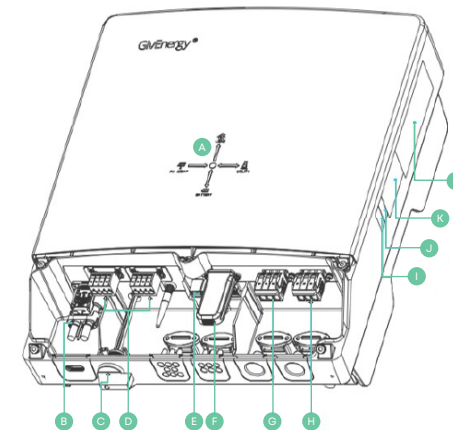

### Safety Instructions

Extra care and attention must be taken when installing and maintaining any GivEnergy equipment. The system is capable of retaining a high voltage, even when disconnected.

- ✔ If you suspect something is wrong with the inverter, contact GivEnergy on **01377 252 874** or email **support@givenergy.co.uk**
- ✔ If there are any damaged or missing parts, please contact GivEnergy on **01377 252 874** or email **support@givenergy.co.uk** immediately. Returns must be provided in original or equivalent packaging.
- ✔ All electrical installations must be carried out by a qualified and registered Electrician and in accordance with the IEE Wiring Regulations
- ✔ During operation, the heat sink may become hot. Do not touch the heat sink at the sides, or the top of the inverter when in operation
- ✔ The inverter is designed to be connected to the grid; connecting your inverter to a generator or other power source can result in damage to the inverter or external devices
- ✔ All GivEnergy equipment must be installed by a GivEnergy Approved Installer



**The inverter must be installed in an easily accessible location, the status display must be visible and not obstructed**



**Please ensure that the wall to be mounted on is sufficient enough to hold the weight of the inverter and battery pack**



**The inverter must be installed in a well ventilated area, the ambient temperature should be below 40°C to ensure optimal operation**



**The inverter must be installed vertically with connections always positioned at the bottom, never install horizontally, and avoid tilting the unit**



**The inverter is recommended to be installed under a canopy if installing externally. Avoid direct sunlight and near water sources**



**Mount the inverter at least 3 feet above ground level (outside only)**

### Precautions

- ✔ It is very important for system safety and efficient operation to use appropriate cables for battery connections. 16mm<sup>2</sup> (minimum) tri-rated cables must be used for DC battery connections
- ✔ The voltage of the battery connected must not exceed 60V (or it will damage the inverter and void any warranty)
- ✔ Only GivEnergy batteries should be connected to our inverters
- ✔ Reversed polarity will damage the inverter
- ✔ The battery must be installed in accordance with the Battery Installation Guide

## STEP-BY-STEP INSTALLATION

Below is a list of the tools and equipment required to install the Gen 3 hybrid inverter

- |                        |                 |                                       |
|------------------------|-----------------|---------------------------------------|
| ✔ Pencil               | ✔ Wire Stripper | ✔ Safety Goggles                      |
| ✔ Electric Screwdriver | ✔ Multimeter    | ✔ Flathead and Crosshead Screwdrivers |
| ✔ Allen Key            | ✔ Spirit Level  | ✔ Tape Measure                        |
| ✔ Impact Drill         | ✔ Pliers        | ✔ Crimping Pliers                     |

1. Wall thickness for mounting the inverter must be no less than 100mm. Place the wall mounting bracket horizontally onto the wall and mark the position of the bracket holes.

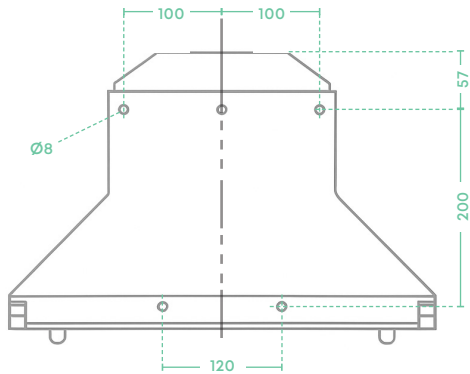

2. Drill 5 holes at the marked positions, at least 80mm deep. Fix the mounting bracket to the wall using 5 x M6x70 expansion bolts.

**Please note:** If fitting the inverter to a non-masonry wall, different fixings will be required.

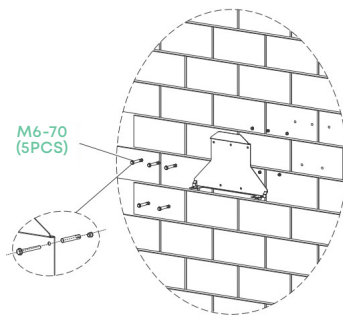

## STEP-BY-STEP INSTALLATION

3. Mount the inverter onto the mounting bracket.

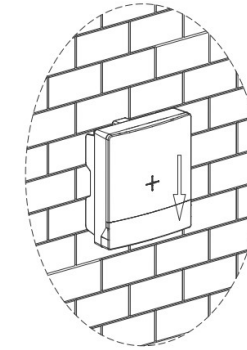

4. Insert the 2 x M4 safety locking screws on the left and right side to prevent the inverter from being lifted off the bracket.

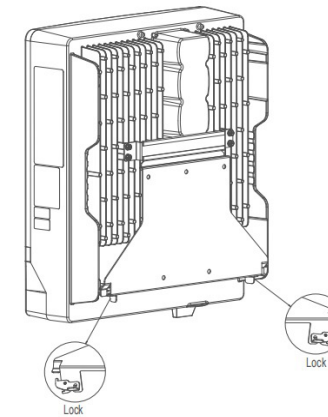

## CLEARANCE AND MAINTENANCE

### Space Clearance

There must be adequate clearance around the inverter to allow for heat dissipation. The diagram below illustrates the space required around the inverter.



### Maintenance

When maintaining and cleaning the inverter, the **whole system must be powered down**. Please refrain from using cleaning products on the surface of the inverter.

To ensure your inverter operates optimally at all times, annual maintenance checks need to be carried out. Check for visible damage or discolouration of the switch, and that the cables are intact. Please ensure that the top of the inverter is not obstructed in any way.

We recommend operating the rotary isolator from ON to OFF 5 times, this cleans the contacts of the rotary switch.

## CONNECTIONS OVERVIEW

Item	Item Name	Item	Item Name
A	2 Hexagon Socket Screws, M6x14	K	PV Input Switch
B	Wiring Chamber	L	All In One Battery Connection
C	Wire Sealing Ring	M	PV Input Terminals
D	Fixed Wire	N	PV Input Terminals
E	2 Phillips Screws, M4x8	O	Built In WIFI Antenna
F	8 Internal Hexagonal Screws, M5x18	P	Signal Connection: CT, BMS, METER, LAN, CAN, DRM, PARALLEL
G	WiFi Serial Number	Q	External WiFi or 4G Module (USB Port)
H	Inverter Serial Number	R	EPS Terminals
I	Warning Signs Label	S	AC Supply Terminals
J	Specification Label		

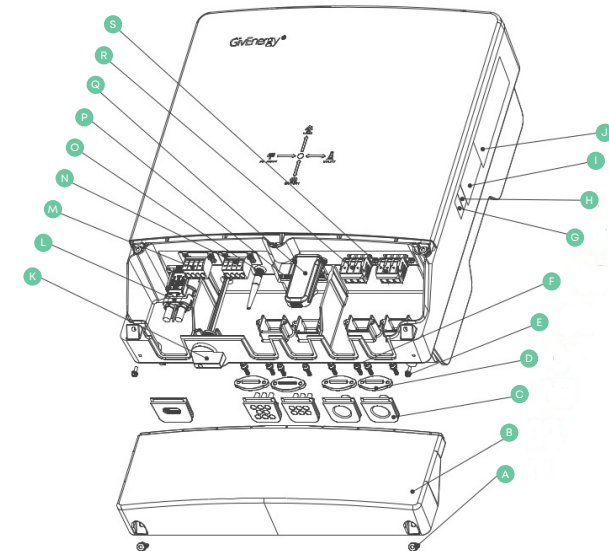

## COMMUNICATION CONNECTIONS

Please ensure the system is turned off before modifying anything.



WiFi

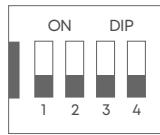

USB

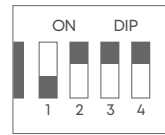

LAN

Item	Function	Foot Position	Note
E1	D11 and D12 Input Port	1: D11+ 2: D11- 3: D12+ 4: D12-	
E2	Meter and EMS Communication Port	1: Meter-RS485+ 2: Meter-RS485- 3: GND 4: EMS-RS485+ 5: EMS-RS485-	
E3	CT and Reserve BMS Communication Port	1: LC+ 2: LC- 3: GND	BMS communication method is CAN or RS485 based on E10 DIP switch

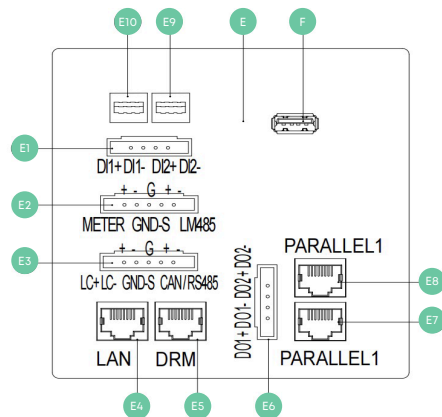

## AC UTILITY GRID CONNECTION

Cable size requirements for the Hybrid Inverter are dependant on the model:

- **HY 8.0** - minimum 6mm<sup>2</sup>
- **HY 10.0** - minimum 10mm<sup>2</sup>

The cable should be sized in accordance with the material used and the length of the run to maintain acceptable voltage drop in accordance with BS7671. Excessive voltage drop will reduce efficiency and cause unwanted cable heat.

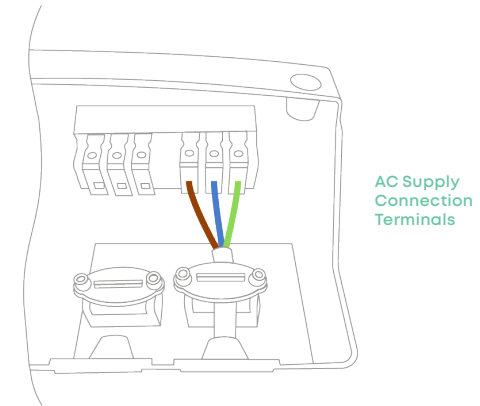

	Maximum Output	Overcurrent Protection	RCD Protection (if required)**	Minimum Cable size*
Hybrid 8.0kW	37A	C40	Type A 30mA	6mm
Hybrid 10.0kW	46A	C50		10mm

\*This is the minimum size cable, large CSA may be required – Refer to BS7671  
\*\*See separate RCD declaration

## CONNECTING TO THE EPS

The Emergency Power Supply (EPS) can provide a maximum output power of 8kw or 10kw during a grid outage depending on the inverter model. The output must be protected as close to the inverter as possible with a double pole RCD/RCBO at 30mA, with suitable overcurrent protection for the installed cable, up to the inverters maximum bypass current rating.

- For the 8kw inverter this is 37A, use a 40A breaker
- For the 10kw inverter this is 46A, use a 50A breaker

There are 4 approved methods to connect the EPS output of the inverter; please refer to the EPS Connection Guide for more details.

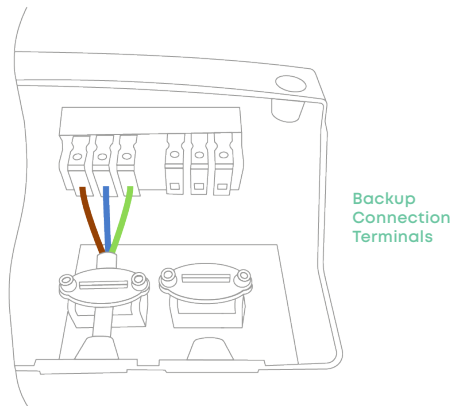

If the backup terminals are used, please ensure the following:

An earth rod must be installed and connected to the main earthing terminal, as close to the origin of supply as possible, and adequate overload / short circuit protection must be installed in accordance with the IEE wiring regulations.



The EPS MAX output power is 8000/10000W. If the load is greater than 8000/10000W the inverter will stop outputting and going to fault. The EPS output will only operate when the battery(s) have capacity available.

Any other grid tied generation must be supplied from the grid side of the changeover switch to avoid damage to the inverter, and void in warranty (see the following diagrams for reference).

## FULL PROPERTY BACKUP

**Correct wiring** of full property back-up with manual or automatic change over switch:

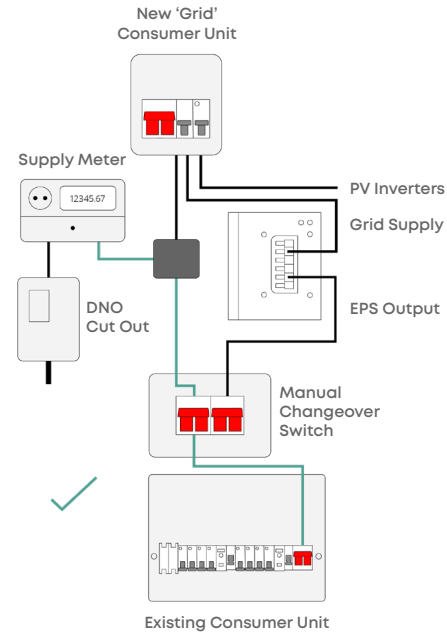

**Incorrect wiring** of full property back-up with manual or automatic change over switch:

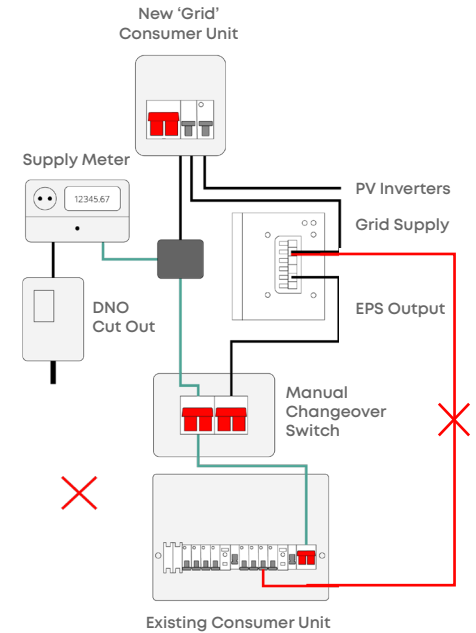

## CONNECTING THE BATTERY TO THE INVERTER

1. Connect the cable to the battery and the other end to the inverter. Ensure that the grommeted end of the cable is the inverter end. Push the plug until there is a click, lock in place using the red tab.

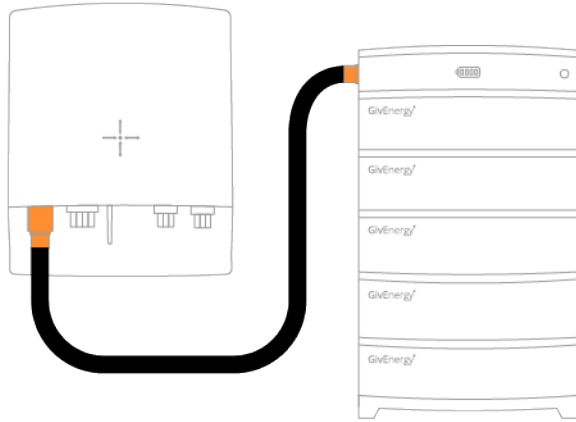

2. Make sure there is one cable (under local legislation, 6mm<sup>2</sup> earth cable suggested) running from one of the earthing points on the bottom of the inverter to the earthing point on the stackable battery.
3. When ready to power up the unit, switch on the isolator on the battery. Push and hold the button for 2 seconds to switch on the battery stack. The lights should then illuminate. The system is now ready for commissioning.



## CONNECTING MULTIPLE BATTERY

1. Connect the cable to the battery and the other end to the inverter. Ensure that the grommeted end of the cable is the inverter end. Push the plug until there is a click, lock in place using the red tab. Connect the second stack to the output connector in the first stack.

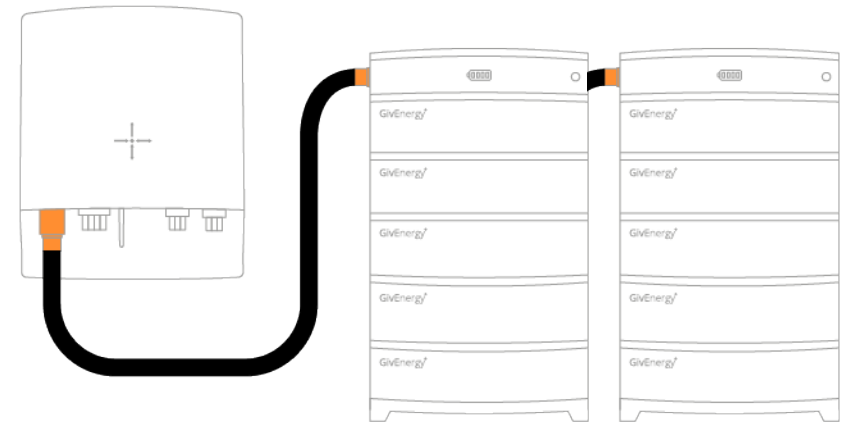

2. Power on is the same as with a single stack.

## CONNECTING MID APPROVED METER

In the system, a mid approved meter must be installed to ensure correct monitoring of the grid power. The inverter uses this information to decide whether to charge or discharge the battery.

The CT clamp that is connected to the mid approved meter must be installed around the live incoming supply to the property, with the arrow pointing in the direction of grid import, in order to monitor the complete consumption of the building.

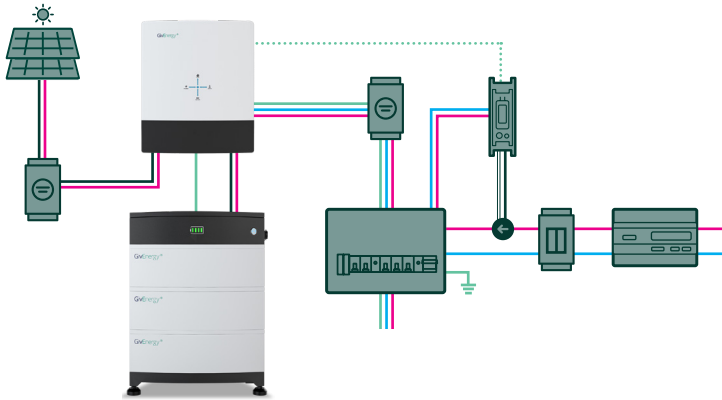

## LABEL DESCRIPTION

### Nameplate

This provides unique identification of the inverter (product type, device-specific characteristics, certificates and approvals). The Nameplate is located on the right side of the inverter.

GivEnergy® PV Hybrid Inverter		GivEnergy® PV Hybrid Inverter	
Model		Model	
GIV-HY-10.0-G3-HV		GIV-HY-8.0-G3-HV	
<b>Input Data(PV)</b>			
Max. PV Open-circuit Voltage	600Vd.c.	Max. PV Open-circuit Voltage	600Vd.c.
Max. PV Short-circuit Current	2+38Ad.c.	Max. PV Short-circuit Current	2+30Ad.c.
Max. PV Input Current	2+30Ad.c.	Max. PV Input Current	2+25Ad.c.
PV Input Voltage Range	80 – 600Vd.c.	PV Input Voltage Range	80 – 600Vd.c.
MPPPT Voltage Range	90 – 550Vd.c.	MPPPT Voltage Range	90 – 550Vd.c.
Number of MPP Trackers	2	Number of MPP Trackers	2
<b>Output Data(AC)</b>			
Rated AC Output Power	10000W	Rated AC Output Power	8000W
Rated/Max. Apparent Power	10000VA	Rated/Max. Apparent Power	8000VA
Nominal AC Voltage	230Va.c.	Nominal AC Voltage	230Va.c.
AC Grid Frequency	50Hz	AC Grid Frequency	50Hz
Rated Output Current	46Aa.c.	Rated Output Current	37Aa.c.
Power Factor Range	0.8lagging–0.8leading	Power Factor Range	0.8lagging–0.8leading
<b>Backup(AC)</b>			
Rated AC Output Power	10000W	Rated AC Output Power	8000W
Rated Apparent Power	10000VA	Rated Apparent Power	8000VA
Nominal AC Voltage	230Va.c.	Nominal AC Voltage	230Va.c.
Nominal AC Frequency	50Hz	Nominal AC Frequency	50Hz
Rated Output Current	46Aa.c.	Rated Output Current	37Aa.c.
<b>Battery</b>			
Battery Type	LI-ion	Battery Type	LI-ion
Rated Voltage	360V	Rated Voltage	360V
Operating Voltage Range	120–510V	Operating Voltage Range	120–510V
Rated Charging/Discharging Current	25Ad.c.	Rated Charging/Discharging Current	25Ad.c.
Rated Charging/Discharging Power	10000/10500W	Rated Charging/Discharging Power	8000/8500W
<b>Others</b>			
Inverter Topology	Non-isolated	Inverter Topology	Non-isolated
Overvoltage Category	DC II , AC III	Overvoltage Category	DC II , AC III
Ingress Protection	IP65	Ingress Protection	IP65
Protective Class	Class I	Protective Class	Class I
Operating Temperature Range	-25~+60 °C	Operating Temperature Range	-25~+60 °C
Serial Number:		Serial Number:	

### Warning Labels

Located under the nameplate of the inverter as shown in the picture:

**CAUTION!**  
 Risk of electric shock. Each circuit must be individually disconnected and the service person must wait 5 minutes before servicing.

**CAUTION!**  
 Risk of electric shock. Do not remove Cover. No user serviceable parts inside. Refer servicing to qualified service personnel.

**CAUTION!**  
 Hot surface. Do not touch.

When the photovoltaic array is exposed to light, it supplies a DC voltage to the PCE.  
 Please look at the safety instructions within the device and also in the inverter manual.

### Serial Number

Located on the right side of the battery, the current battery serial number information

**GIV: HY - 10.0 - G3-HV**

1 2

Number	Paraphrase	Instructions
1	Inverter Type	Single-Phase Energy Storage Inverter
2	Rated Output Power	10.0: Rated Output Power 10.0kW

## START-UP AND SHUT-DOWN OF THE INVERTER

---

### Start-Up Procedure

1. Connect the AC circuit breaker, ensure that the system is powered and commissioned using the portal/App. Ensure that the grid power is reading identical to that of the mid approved meter (this can be found on the screen of the meter).
2. Turn on the DC switch.
3. Turn on the battery breaker.
4. Turn on the battery.
5. The inverter will start automatically when the PV voltage is higher than 90V.

### Shutdown Procedure

1. Turn off the battery.
2. Disconnect the AC circuit breaker to prevent it from being reactivated.
3. Disconnect the battery breaker to prevent it from being reactivated.
4. Turn off the PV switch.
5. Check the inverter operating status.
6. Wait until all LEDs have gone out. The inverter is now shut down.

## GROUNDING REQUIREMENTS

---

- Equipment to be grounded, when installing, must first install a protective ground wire; When removing equipment, the protective ground wire must be removed last
- The grounding of the energy storage inverter meets the local requirements for the grounding of photovoltaic modules and energy storage inverters. To ensure continuous conduction with the ground in order to optimally protect the system and personnel.

**The system must not be operated without being grounded.**

## COMMISSIONING A SYSTEM

All systems must be commissioned to ensure correct battery and meter communications, as well as connection to the online portal.

**Note: Without commissioning, the system may not operate correctly.**

Check that all the wires are securely connected before the battery breaker and the AC isolator is switched on. You MUST set the parameters of the battery according to your battery system.

### Accessing the Commissioning Portal

Sign into the online portal at <https://portal.givenergy.cloud> with your GivEnergy Engineer login. If you are a first time user, and you do not have an account or Engineer login, please consult your supplier to get this set up.

✔ To download a fully illustrated guide, please visit the Resource Hub on the GivEnergy website.

## DECOMMISSIONING A SYSTEM

### Uninstalling the Inverter

1. Follow the shut-down procedure.
2. Remove all connections and cables from the inverter.
3. Remove the locking pins which are securing the inverter to the bracket.
4. Lift the inverter off the bracket.
5. Remove the wall bracket.

### Packaging the Inverter

If possible, always pack the inverter in its original packaging and secure it with tension belts. If this is not available, you may also use an equivalent sized box. The box must be capable of being closed completely and be strong enough to support both the weight and the size of the inverter.

### Storing the Inverter

Store the inverter in a dry place where ambient temperatures are always between -25°C and +60°C.

## WORK MODES



### Eco Mode

The system optimises the delivery of generated PV power and battery power to prioritise the home load. Grid power is used as a last resort if solar and battery power are unavailable.



### Off Peak Charging

This is prioritised to charge the battery during off peak times when energy is cheaper, greener, and cleaner. The battery will start to discharge outside of the off peak time when energy is more expensive.



### Back Up / Island Mode

The system has the ability to be used in the event of a power cut. To utilise this feature, circuits must be connected to the inverter's EPS terminals.

To download a fully illustrated guide on connecting the inverter to the EPS, please visit the Resource Hub on the GivEnergy website.

## MANUFACTURER WARRANTIES

This inverter is covered by a 12-year warranty.



# GivEnergy

---

**Phone**

UK +44 01377 252 874

NL +31 85 208 6376

**Email**

UK [support@givenergy.co.uk](mailto:support@givenergy.co.uk)

NL [support@givenergy.com](mailto:support@givenergy.com)

SA [support.sa@givenergy.com](mailto:support.sa@givenergy.com)

AU [martin.cobb@givenergy.com](mailto:martin.cobb@givenergy.com)

**Website**

[www.givenergy.com](http://www.givenergy.com)