



GENERATION 3

Hybrid Inverter Installation Manual

HY 3.6 | HY 5.0

SPECIFICATIONS



A TRUE MULTI-TASKER Battery and Solar Inverter in One

The third generation of the GivEnergy Hybrid Inverter is a battery and solar inverter in one unit.

It can be coupled directly with solar panels to generate electricity in the property during daylight hours, as well as store any excess energy for later use in our batteries to minimise export. Additionally, it will minimise import by discharging to meet demand in the property.

The Hybrid Inverter GEN 3 is connected to our batteries using an all-in-one plug, for an easier installation process.

SPECIFICATION

Dimensions

588H x 214D x 480W (mm)

Warranty

12 years

Weight

32Kg

Max. DC Input Power

15kW

Operational Temperature

-20°C - +60°C

Start Up Voltage

3.6kW - 150V

5.0kW - 150V

BOX CONTENTS

Item	Item Name	Qty
A	Inverter	1
B	Mounting Bracket Fixings	5
C	Bonding Kit	1

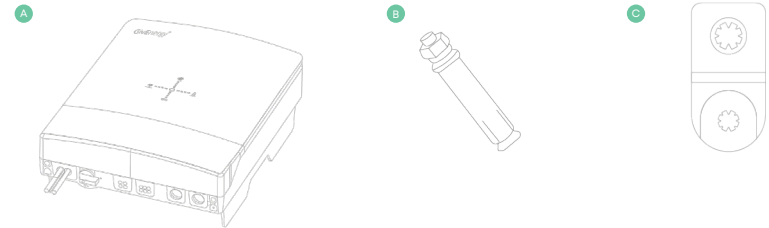

Introduction

All information contained in this booklet refers to the assembly, installation, commissioning, and maintenance of the Generation 3 Hybrid Inverter. Please retain this manual for future reference.

Legal Disclaimer: This document is the property of GivEnergy, reproduction is prohibited.

Installation Requirements

Installation of all GivEnergy equipment must be carried out by a **GivEnergy Approved Installer**.

Unit Information

The Hybrid Inverter is a battery and PV inverter in one. It is bi-directional, meaning it can charge from the grid (AC coupled) and from solar (DC coupled). The energy generated by photovoltaic systems is used to optimize self consumption. The excess energy is used to charge the battery and then fed into the public grid when the photovoltaic energy is sufficient.

When the photovoltaic energy output is insufficient to support the connected load, if the battery capacity is sufficient, the system will automatically obtain energy from the battery. If the battery capacity is insufficient to meet its own consumption needs, electricity will be extracted from the public grid.

Storing the Inverter

The unit must be stored in its original packaging at temperatures between 5°C - 60°C. Do not stack more than 4 units on top of each other.

Packaging Contents

When unpacking, please check the following:

- ✔ There are no missing accessories from the packaging list
- ✔ The model and specification of the inverter's nameplate match the order specifications

If any damaged or missing parts are found, please contact GivEnergy on **01377 252 874** or email **support@givenergy.co.uk** immediately. Returns must be provided in original or equivalent packaging. The cardboard packaging is recyclable.

Item	Item Name
A	Power Flow Direction Indicators
B	All in One Battery Connection
C	PV Isolator
D	PV Input Terminals
E	USB Port for 4G Module (Optional)
F	Meter Communications and LAN
G	AC Supply Terminals (Right) and EPS Terminals (Left)
H	Serial No.
I	WiFi Serial No. and Verification Code
J	Warning Signs Label
K	Specification Label

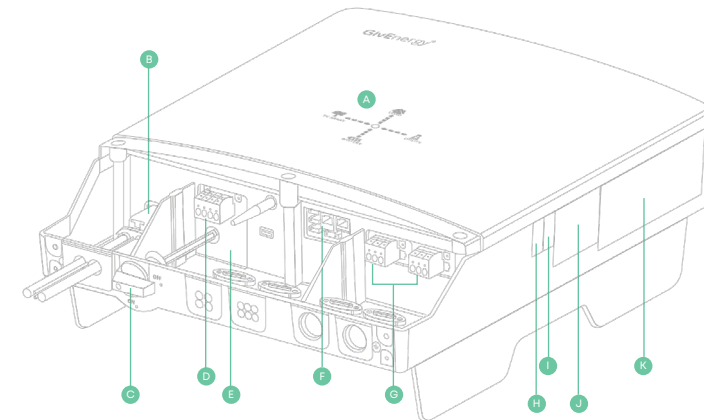

Safety Instructions

Extra care and attention must be taken when installing and maintaining any GivEnergy equipment. The system is capable of retaining a high voltage, even when disconnected.

- ✔ If you suspect something is wrong with the inverter, contact GivEnergy on **01377 252 874** or email **support@givenergy.co.uk**
- ✔ If there are any damaged or missing parts, please contact GivEnergy on **01377 252 874** or email **support@givenergy.co.uk** immediately. Returns must be provided in original or equivalent packaging.
- ✔ All electrical installations must be carried out by a qualified and registered Electrician and in accordance with the IEE Wiring Regulations
- ✔ During operation, the heat sink may become hot. Do not touch the heat sink at the sides, or the top of the inverter when in operation
- ✔ The inverter is designed to be connected to the grid; connecting your inverter to a generator or other power source can result in damage to the inverter or external devices
- ✔ All GivEnergy equipment must be installed by a GivEnergy Approved Installer



The inverter must be installed in an easily accessible location, the status display must be visible and not obstructed



Please ensure that the wall to be mounted on is sufficient enough to hold the weight of the inverter and battery pack



The inverter must be installed in a well ventilated area, the ambient temperature should be below 40°C to ensure optimal operation



The inverter must be installed vertically with connections always positioned at the bottom, never install horizontally, and avoid tilting the unit



The inverter is recommended to be installed under a canopy if installing externally. Avoid direct sunlight and near water sources



Mount the inverter at least 3 feet above ground level (outside only)

Precautions

- ✔ It is very important for system safety and efficient operation to use appropriate cables for battery connections. 16mm² (minimum) tri-rated cables must be used for DC battery connections
- ✔ The voltage of the battery connected must not exceed 60V (or it will damage the inverter and void any warranty)
- ✔ Only GivEnergy batteries should be connected to our inverters
- ✔ Reversed polarity will damage the inverter
- ✔ The battery must be installed in accordance with the Battery Installation Guide

STEP-BY-STEP INSTALLATION

1. Wall thickness for mounting the inverter must be no less than 100mm. Remove the wall mounting bracket from the back of the inverter and place horizontally onto the wall and mark the position of the bracket holes.

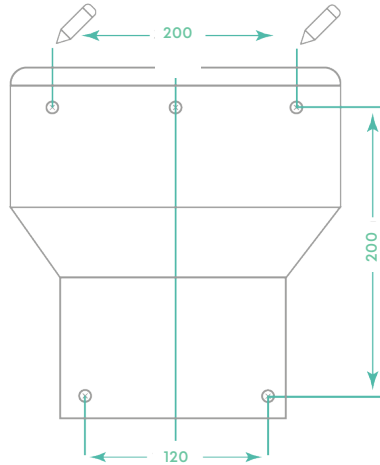

2. Drill 5 holes at the marked positions, at least 75mm deep. Fix the mounting bracket to the wall using 5 x M6x50 expansion bolts.

Please note: If fitting the inverter to a non-masonry wall, different fixings will be required.

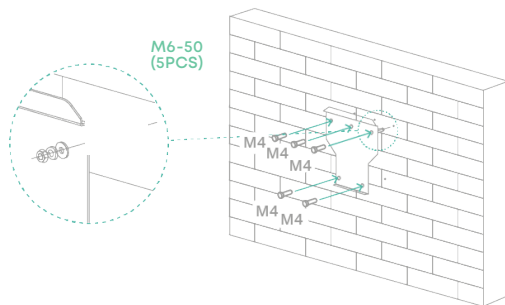

STEP-BY-STEP INSTALLATION

3. Mount the inverter onto the mounting bracket.

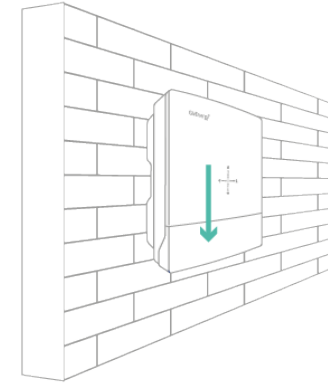

4. Insert the 2 x M4 safety locking screws on the left and right side to prevent the inverter from being lifted off the bracket.

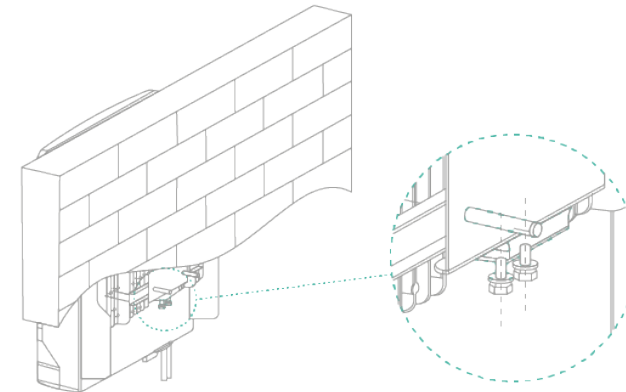

CLEARANCE AND MAINTENANCE

Space Clearance

There must be adequate clearance around the inverter to allow for heat dissipation. The diagram below illustrates the space required around the inverter.



Maintenance

When maintaining and cleaning the inverter, the **whole system must be powered down**. Please refrain from using cleaning products on the surface of the inverter.

To ensure your inverter operates optimally at all times, annual maintenance checks need to be carried out. Check for visible damage or discolouration of the switch, and that the cables are intact. Please ensure that the top of the inverter is not obstructed in any way.

We recommend operating the rotary isolator from ON to OFF 5 times, this cleans the contacts of the rotary switch.

CONNECTIONS OVERVIEW

Item	Item Name
A	All-In-One Battery Connector
B	PV Input
C	Built-In WiFi Aerial
D	Meter Communication and LAN Connectors for Router
E	EPS Connection
F	AC Connection
G	DC Input Isolation Switch
H	IP65 Cable Entry Glands
I	Cable Clamps

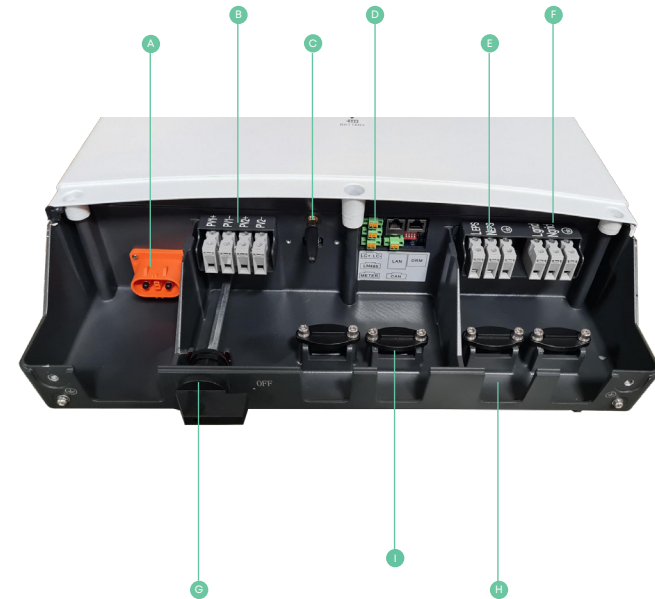

COMMUNICATION CONNECTIONS

Please ensure the system is turned off before modifying anything.

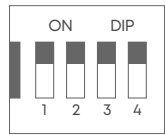

WiFi

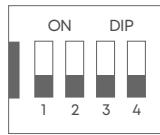

USB

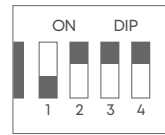

LAN

Communication/Network Ports

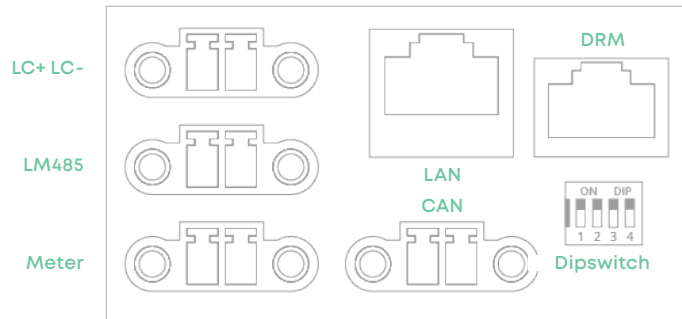

AC UTILITY GRID CONNECTION

Cable size requirements for the Hybrid Inverter are dependant on the model:

- ✔ **HY 5.0** - minimum 4mm² - 6mm²
- ✔ **HY 3.6** - minimum 2.5mm² - 4mm²

The recommended maximum cable length should not exceed 50m as the resistance of the cable will consume inverter output power and reduce the inverter efficiency.

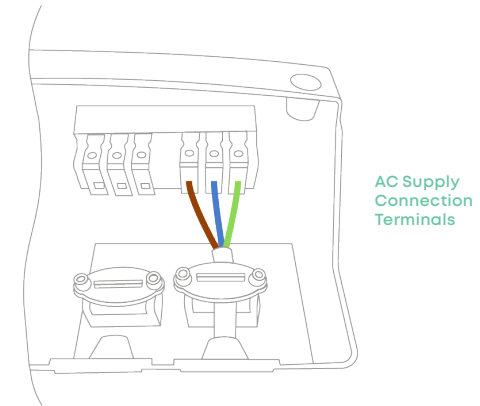

	Maximum Output	Overcurrent Protection	RCD Protection (if required)**	Minimum Cable size*
Hybrid 3.6kW	16.4A	C20	Type A 30mA	2.5mm
Hybrid 5.0kW	22.8A	C25 or C32		4mm
AC Connect 3.0kW	13A	C20		2.5mm

*This is the minimum size cable, large CSA may be required – Refer to BS7671

**See separate RCD declaration

CONNECTING TO THE EPS

The Emergency Power Supply (EPS) can provide a maximum output power of 3600W during a grid failure. This output must be protected as close to the inverter as possible, with a double pole 30mA RCD rated at up to 20A.

There are four approved methods to connect to the EPS, please refer to the EPS Connection Guide on our Resource Hub for more information.

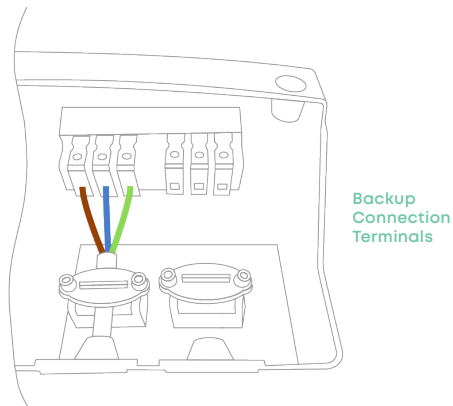

If the backup terminals are used, please ensure the following:

An earth rod must be installed and connected to the main earthing terminal, as close to the origin of supply as possible, and adequate overload / short circuit protection must be installed in accordance with the IEE wiring regulations.



The EPS MAX output power is 3600W. If the load is greater than 3600W the inverter will stop outputting and going to fault. The EPS output will only operate when the battery(s) have capacity available.

Any other grid tied generation must be supplied from the grid side of the changeover switch to avoid damage to the inverter, and void in warranty (see the following diagrams for reference).

FULL PROPERTY BACKUP

Correct wiring of full property back-up with manual or automatic change over switch:

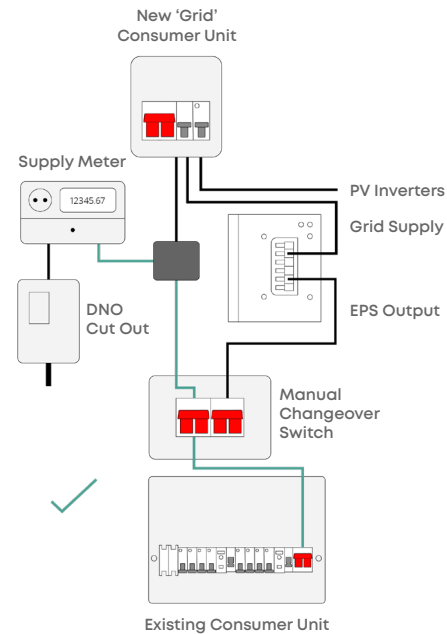

Incorrect wiring of full property back-up with manual or automatic change over switch:

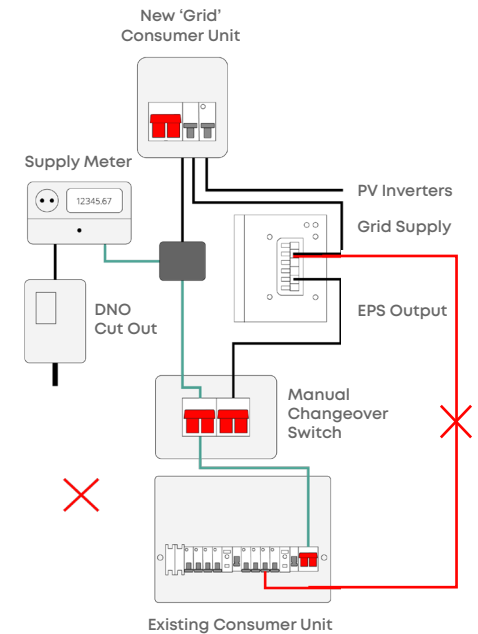

CONNECTING THE BATTERY TO THE INVERTER

1. A DC MCB must be installed between the master battery and the inverter of Gen 1 batteries (not less than 100A), this will ensure the inverter can be safely disconnected during maintenance.

Please note that a separate DC MCB is not required with Gen 2 batteries as they have one integrated, unless Gen 1 batteries are installed after a Gen 2 battery pack.

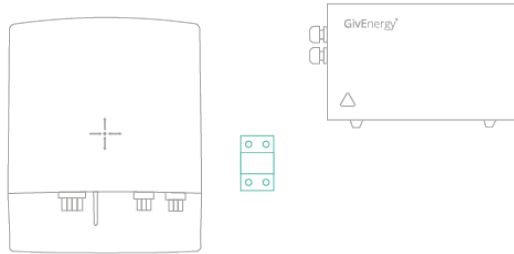

Generation 1 Battery Only

2. Check the battery nominal voltage and polarity. When connecting a Gen 3 inverter to a Gen 1 battery (2.6kWh, 5.2kWh, 8.2kWh), an all in one to ring terminal connection must be used.

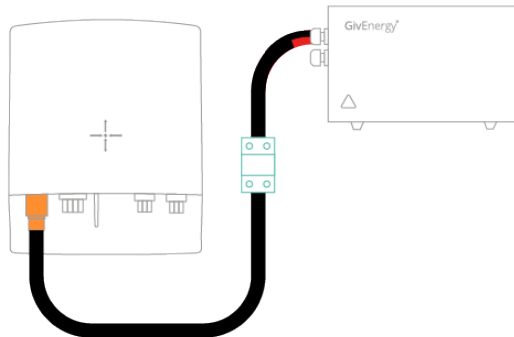

CONNECTING THE BATTERY TO THE INVERTER

Generation 2 Battery Only

3. When connecting a Gen 3 inverter to a Gen 2 battery (9.5kWh), an all in one to all in one cable must be used. Connect the all in one plug into the all in one connection on the inverter. The other end can then be connected to the A-socket on the Gen 2 battery (ensure that the red clip is facing away from the inverter, and is pushed in securely).

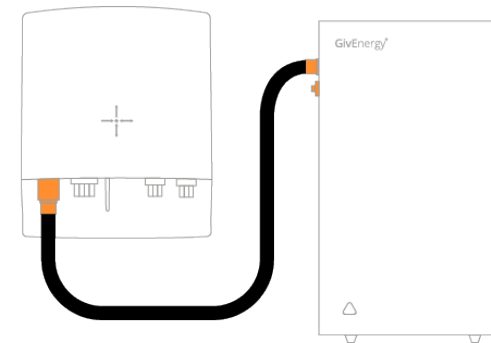

Installation of Additional Batteries

4. If connecting additional batteries, you will require an all in one to all in one cable (Gen 2 battery), or an all in one to ring terminal cable (Gen 1 battery). There is no requirement for a DC MCB to be installed between additional batteries.

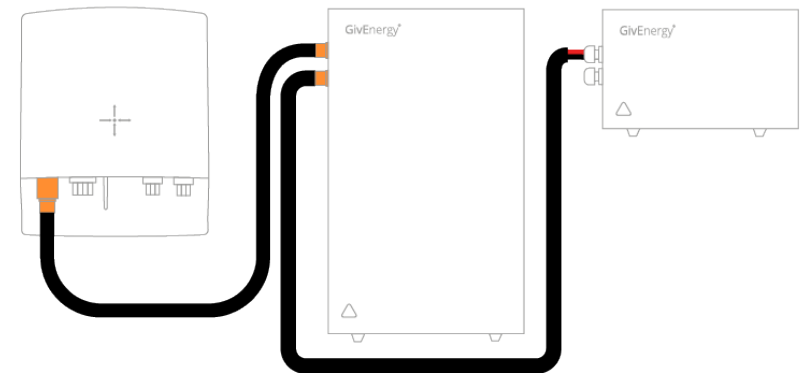

CONNECTING MID APPROVED METER TO INVERTER

In the system, a mid approved meter must be installed to ensure correct monitoring of the grid power. The inverter uses this information to decide whether to charge or discharge the battery.

The CT clamp that is connected to the mid approved meter must be installed around the live incoming supply to the property, with the arrow pointing in the direction of grid import, in order to monitor the complete consumption of the building.

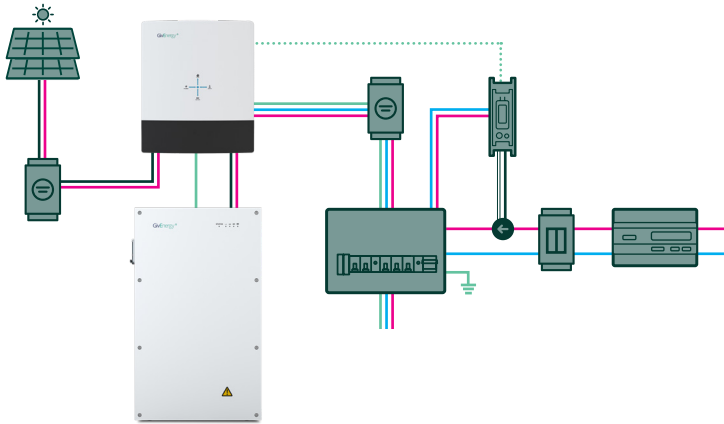

START-UP AND SHUT-DOWN OF THE INVERTER

Start-Up Procedure

1. Connect the AC circuit breaker, ensure that the system is powered and commissioned using the portal/App. Ensure that the grid power is reading identical to that of the mid approved meter (this can be found on the screen of the meter).
2. Turn on the PV switch.
3. Turn on the battery breaker.
4. Turn on the battery.
5. The inverter will start automatically when the PV voltage is higher than 150V, and the battery voltage is higher than 46.4V

Shutdown Procedure

1. Turn off the battery.
2. Disconnect the AC circuit breaker to prevent it from being reactivated.
3. Disconnect the battery breaker to prevent it from being reactivated.
4. Turn off the PV switch.
5. Check the inverter operating status.
6. Wait until all LEDs have gone out. The inverter is now shut down.

EARTH BONDING

The bonding kit is to be fixed after the wiring of the inverter.

Earth Bonding the Inverter

1. Unscrew the hex screw from the inverter's bottom cover on the left hand side and remove the screw from the external earthing point.
2. Align the bonding plate with the fixing holes on the bottom of the inverter, then fix in place with the M6 x 12 hex screw and serrated washer supplied with the kit.
3. Fasten the other end of the bonding plate by reinserting the earthing point screw (please ensure that the serrated washer is secure).
4. Test continuity between earth bonding screw and the supply earth at the AC isolator and record the resistance value (required later for commissioning) . A value around 0.1 ohms is acceptable.
5. Take a photo of the earth bonding kit installed as this needs to be submitted during the commissioning process.

COMMISSIONING A SYSTEM

All systems must be commissioned to ensure correct battery and meter communications, as well as connection to the online portal.

Note: Without commissioning, the system may not operate correctly.

Check that all the wires are securely connected before the battery breaker and the AC isolator is switched on. You MUST set the parameters of the battery according to your battery system.

Accessing the Commissioning Portal

Sign into the online portal at <https://portal.givenergy.cloud> with your GivEnergy Engineer login. If you are a first time user, and you do not have an account or Engineer login, please consult your supplier to get this set up.

- ✔ To download a fully illustrated guide, please visit the Resource Hub on the GivEnergy website.

Uninstalling the Inverter

1. Follow the shut-down procedure.
2. Remove all connections and cables from the inverter.
3. Remove the locking pins which are securing the inverter to the bracket.
4. Lift the inverter off the bracket.
5. Remove the wall bracket.

Packaging the Inverter

If possible, always pack the inverter in its original packaging and secure it with tension belts. If this is not available, you may also use an equivalent sized box. The box must be capable of being closed completely and be strong enough to support both the weight and the size of the inverter.

Storing the Inverter

Store the inverter in a dry place where ambient temperatures are always between -25°C and +60°C.



Eco Mode

The system optimises the delivery of generated PV power and battery power to prioritise the home load. Grid power is used as a last resort if solar and battery power are unavailable.



Off Peak Charging

This is prioritised to charge the battery during off peak times when energy is cheaper, greener, and cleaner. The battery will start to discharge outside of the off peak time when energy is more expensive.



Back Up / Island Mode

The system has the ability to be used in the event of a power cut. To utilise this feature, circuits must be connected to the inverter's EPS terminals.

To download a fully illustrated guide on connecting the inverter to the EPS, please visit the Resource Hub on the GivEnergy website.

MANUFACTURER WARRANTIES

This inverter is covered by a 12-year warranty.



Hybrid Inverter Gen 3 / 3.6 | 5.0
12-year warranty

GivEnergy

Phone

UK +44 01377 252 874
NL +31 85 208 6376

Email

UK support@givenergy.co.uk
NL support@givenergy.com
SA support.sa@givenergy.com
AU martin.cobb@givenergy.com

Website

www.givenergy.com