



FAST AND RELIABLE

EV Charger Installation Manual

7.2KW | V7.0

CONTENTS

EV CHARGER

Specifications	3
EV Charger Features	4
Box Contents and Components	5
General Information	6
Pre-Installation Checklist	7
Safety and Installation	8
Installation Instructions	9
Step-By-Step Installation	10
Installation Configuration	14
EM115/GEM120 Grid Meter Installation	15
Setup Guide	16
In-App Setup Guide	18
Modes and Features	19
Operation	20
Troubleshooting	21
Manufacturer warranties	23

SPECIFICATIONS



FAST AND RELIABLE

A great addition to any smart home

The EV charger is a new member of the GivEnergy family. Compatible with most plug-in electric cars, the EV charger is a great addition to your smart home system and GivEnergy ecosystem.

Its compact and waterproof design allows for installation in tight spaces both indoors and outdoors. Integrated WiFi allows for easy control of your vehicle's charge via the GivEnergy monitoring portal or app.

SPECIFICATION

Dimensions

288H x 112D x 260W (mm)

Warranty

3 years

Weight

4.5Kg

Operational Temperature

-30°C to 55°C

AC Input Nominal Voltage

230V

Charging Cable Length

5m

AC Input Range

207 - 253 V

Connectivity

LAN (RJ-45), WiFi

AC Output Range

7.2kW / 32A

Connector Type

IEC 62196-2 (Type 2)

EV CHARGER FEATURES

The GivEnergy EV charger is primarily controlled using the GivEnergy app & cloud resources.

The specific features & functionality available with your GivEnergy charger will vary depending on your installation configuration.

Below is a summary of the functionality that will be available per configuration. Please see the Installation Configuration section for more detail on the hardware required for each configuration.

Basic Installation With No Solar

- EVC installed with internet connectivity only
- Charge modes available: Grid, Schedule
- Controlled by: RFID Tag, App (iOS / Android)

Installation with Third-Party Solar Inverter and has a dedicated EV Charger Grid Meter

- EVC installed with internet connectivity and a compatible meter (Wired or LoRa)
- Charge modes available: Grid, Schedule, Hybrid, Solar
- Controlled by: RFID Tag, App (iOS / Android)

Installation with GivEnergy Inverter (Cloud Based Control)

- EVC installed with internet connectivity and compatible GivEnergy PV inverter associated with the same 'givenergy.cloud' account
- Charge modes available: Grid, Schedule, Hybrid, Solar (cloud control)
- Controlled by: RFID Tag, App (iOS / Android)

BOX CONTENTS & COMPONENTS

Item	Item Name	Qty
A	EV Charger Tethered	1
B	Mounting Bracket	1
C	RFID Cards	2

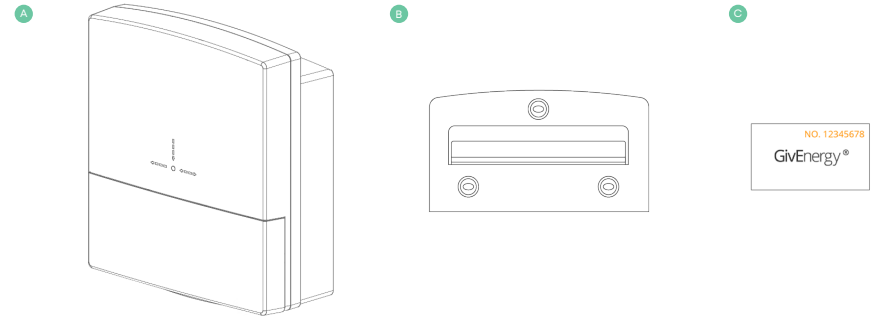

Components

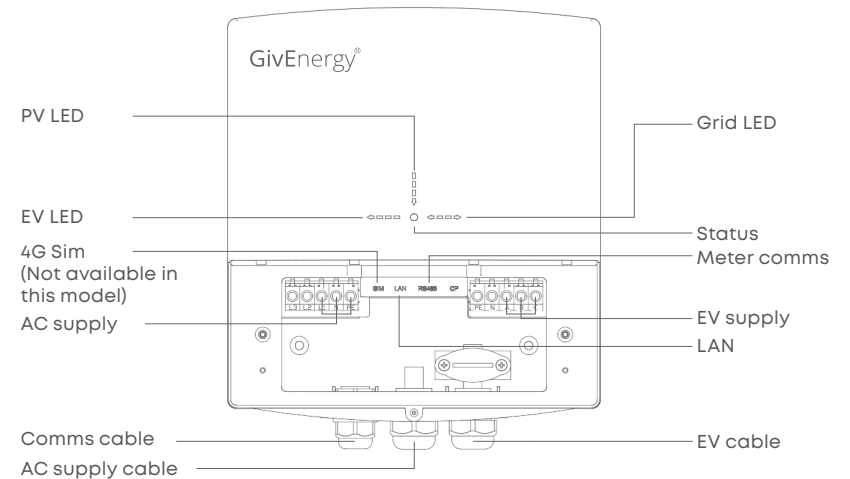

Introduction

All information contained in this booklet refers to the installation and maintenance of GivEnergy's EV charger. Please retain this manual for future reference.

Legal Disclaimer: This document is the property of GivEnergy, reproduction is prohibited.

Installation Requirements

Installation of the GivEnergy EV charger must be carried out by a **qualified electrician** and in accordance with the IEE Wiring Regulations. Suitable RCD protection must be selected in line with BS7671. GivEnergy recommends a 32A Type A RCD/RCBO to protect the EV charger.

Unit Information

The EV charger is used to supply power from a renewable/green energy source to an electric vehicle. The EV charger can be used in both a residential and commercial environment. To charge the vehicle, insert the type 2 plug into the vehicle's connector and control using the RFID card or GivEnergy app/portal.

Storing the Inverter

The unit must be stored in its original packaging at temperatures between -40°C - 70°C. Do not stack more than 4 units on top of each other.

Packaging Contents

When unpacking, please check the following:

- There are no missing accessories from the packaging list
- The model and specification of the EV charger's nameplate match the order specifications

If any damaged or missing parts are found, please contact GivEnergy on **01377 252 874** or email **support@givenergy.co.uk** immediately. Returns must be provided in original or equivalent packaging. The cardboard packaging is recyclable.

Before beginning the installation, the installer should:

- Prompt the homeowner to download the GivEnergy app from the App Store (iOS & Android)
- If the homeowner is a new GivEnergy customer, prompt them to create a GivEnergy account via the GivEnergy app and follow the new EV charger flow
- Discuss and agree the homeowner's preferences on installation, configuration, and the associated functionality that will be available on their choices
- Agree the charger siting location viability and preference
- Check the homeowner's WiFi signal at the planned EVC location and determine whether WiFi or LAN installation is required
- Plan and check wiring runs to the consumer unit, router, and inverter (where appropriate as per the installation configuration)
- Confirm the grid supply fuse for max current limiting of the charger. This is the main fuse rating of the property. This value is required to commission the charger. The charger is capable of limiting the charge current when the current is near the set limit.
- Confirm that the homeowner will be present once the system is physically installed, to activate the system via the app and to input the WiFi SSID and password

SAFETY AND INSTALLATION

Safety Instructions

Extra care and attention must be taken when installing and maintaining any GivEnergy equipment. Please ensure that the charger is fully isolated before removing any of the front covers.

- ✔ If you suspect something is wrong with the charger, contact GivEnergy on **01377 252 874** or email **support@givenergy.co.uk**
- ✔ If there are any damaged or missing parts, please contact GivEnergy on **01377 252 874** or email **support@givenergy.co.uk** immediately. Returns must be provided in original or equivalent packaging.

General Warnings and Safety Notices

- ✔ The GivEnergy EV charger should only be installed and maintained by a suitably competent electrician or EV charger installer, failure to comply will VOID the product warranty
- ✔ The GivEnergy EV charger should be installed in accordance with the latest IEE wiring regulations (BS7671)
- ✔ The GivEnergy EV charger has an inbuilt PEN protective device which will safely disconnect the charger if any current is detected on the earthing conductor, this also means that an earth rod is not required as part of the installation
- ✔ The GivEnergy EV charger has an inbuilt tamper switch which will safely disconnect the charger from the vehicle if the front cover is removed whilst in operation, the customer will also receive a tamper notification in the GivEnergy app, if the switch is engaged

INSTALLATION INSTRUCTIONS

- ✔ Ensure the charger is always fixed to the wall using the mounting bracket
- ✔ Externally mounted chargers must always be wall mounted above the frost-line, or a minimum of 50mm
- ✔ The PE terminal of the EV charger must be grounded securely
- ✔ Ensure all components are attached securely



Do not install in direct sunlight or near water sources



Do not use the charger if there are any deformities, such as bulging or leakages



Do not puncture the charger



Do not throw the charger or use forceful impact



Do not attempt to repair the charger yourself (please call a qualified electrician)



The charger must be installed vertically, never install horizontally, and avoid tilting the unit

STEP-BY-STEP INSTALLATION

1. **Check network:** If WiFi is weak at the charger location, consider running a CAT5/6 cable to the site for LAN or installing a WiFi repeater to aid with signal strength.

A WiFi connection or LAN is **mandatory** for app setup. In the scenario where home WiFi is weak or missing at the charger's location, use a phone hotspot or wireless repeater to perform the first setup. After the first setup, the charger will use LAN and the hotspot/repeater can be removed. If using LAN to set up, a WiFi password is not required during the setup process and can be left blank during this step.

2. **Mount bracket:** Place the wall mounting bracket horizontally onto the wall and mark the position of the bracket holes. Drill 3 holes at the marked positions, at least 75mm deep. Fix the mounting bracket to the wall using the fixings provided.

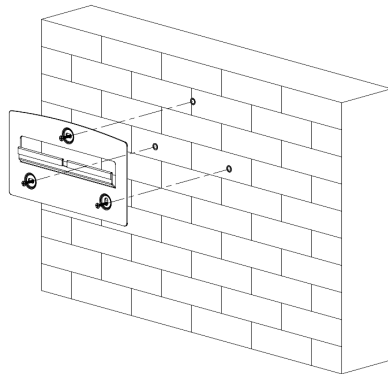

STEP-BY-STEP INSTALLATION

3. **Mount charger:** Remove the decorative cover and the sealing cover from the charger, retaining all screws. Mount the charger onto the mounting bracket. Drill 2 holes at the marked positions, at least 75mm deep. Secure the charger to the wall using wall screws.

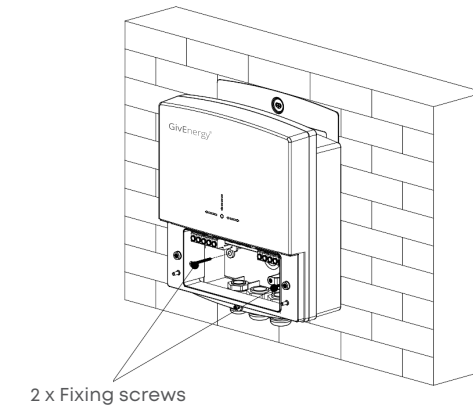

4. **Wire charger:** Pass the power cable through the rubber grommet. Remove the 12mm insulation layer on the wire. Insert the wire into the corresponding terminal. Tighten the screws to ensure there is a stable connection. Attach any RS485 and/or LAN cable as required for the installation configuration selected (see Installation Configuration section).

STEP-BY-STEP INSTALLATION

5. Wiring diagram

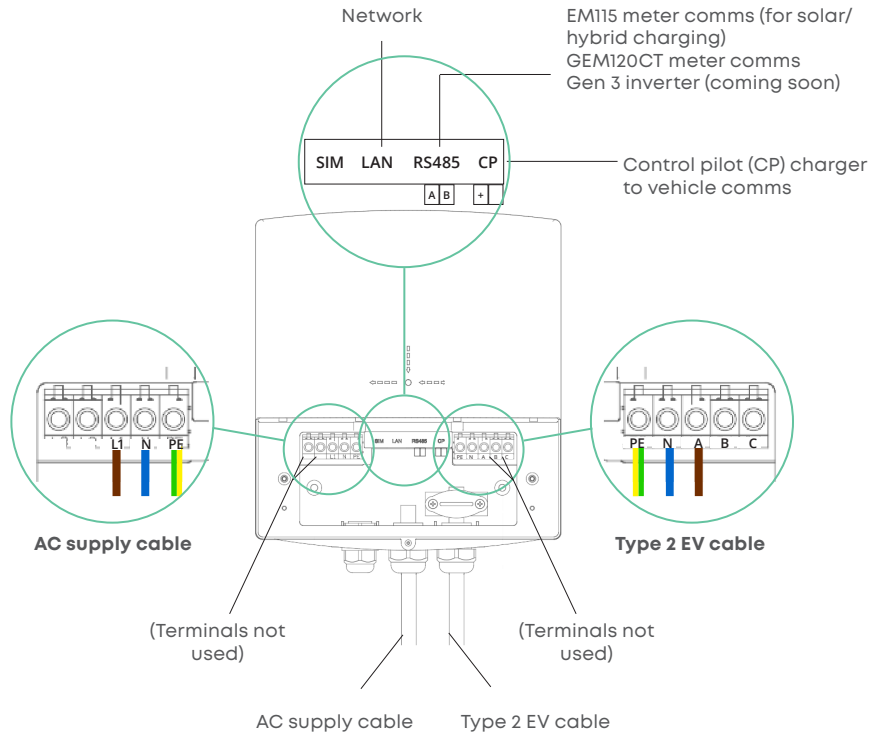

6. Run cables from charger to home

- Power cable (32A) to the charger from grid feed
- LAN cable from charger to home router if required (see step 1)
- Any additional cables required by the selected installation configuration (see Installation Configuration section)

Cables should be specified according to their usage and connected. Please note: it is recommended to install an appropriately specified RCD/RCBO on the input side of the power cable.

STEP-BY-STEP INSTALLATION

7. Test charger

- Turn on the supply to the charger (RCD/RCBO)
- The EV charger should power up and beep once or twice as below:
 - 1 beep means the charger cannot detect a grid meter
 - 2 beeps means the charger can detect a grid meter

- ### 8. Finalise installation:
- Fix the sealing cover to the charger with the previously removed screws. Attach the outer cover to the charger, ensuring that it locks into place. Secure outer cover with the previously removed security torx screw. Whilst securing the sealing cover, please ensure that the tamper switch is securely pressed down into position. The tamper proof switch is included to comply with the smart charging regulations and must be engaged. If the tamper switch disengages, the charger will stop charging and the user will be notified of a tamper event.

9. User handover

- Prompt the customer to finalise setup in the GivEnergy app. The homeowner should be present at the end of installation so that:
 - They can log in to their GivEnergy account on their mobile device (in order to associate the charger with their account)
 - They can enter their home WiFi password during setup
 - The installer can walk them through the app setup and advise / assist if technical parameters require adjustment
- Confirm that the customer can access the new charger in the GivEnergy app
- Provide a walkthrough on the app to inform the customer of the charger features that will be available to them (see Installation Configuration section).

INSTALLATION CONFIGURATION

Basic Installation with No Solar

- Supply cables run between the consumer unit and the EV charger. A Cat 5/6 cable runs between the router and the EV charger if using LAN.

Installation with Third-Party Solar Inverter and has a dedicated EV Charger Grid Meter

- Supply cables run between the consumer unit and the EV charger. A Cat 5/6 cable runs between the router and the EV charger if using LAN.
- Appropriate meter (EM115/GEM120) sited near the consumer unit or cut out.
- EM115/GEM120 meter CT clamp attached to the live supply tail with the arrow pointing towards the consumer unit grid feed cable (to monitor export).
- Data/comms cable from the EM115/GEM120 meter to the charger RS485 port (Cat 5/6 cable).

Installation with GivEnergy Inverter (Cloud Based Control)

- Supply cables run between the consumer unit and the EV charger. A Cat 5/6 cable runs between the router and the EV charger if using LAN.

EV to GEM120CT comms

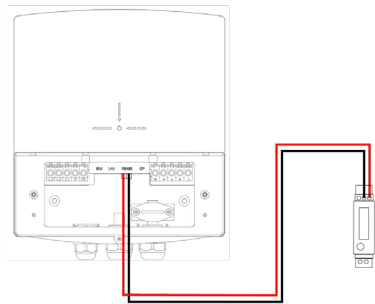

EV to EM115 comms

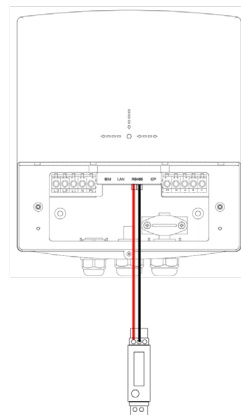

EM115/GEM120 GRID METER INSTALLATION

- Arrow always points towards the load
- CT clamp cables must not be cut down or extended
- EM115/GEM120 meters come with a split core CT that has a 2m cable
- The communication cable for the GEM120 uses the same communication terminals as the EM115 (Terminal 9 and 10) however, the GEM120 communication terminals are on the opposite side

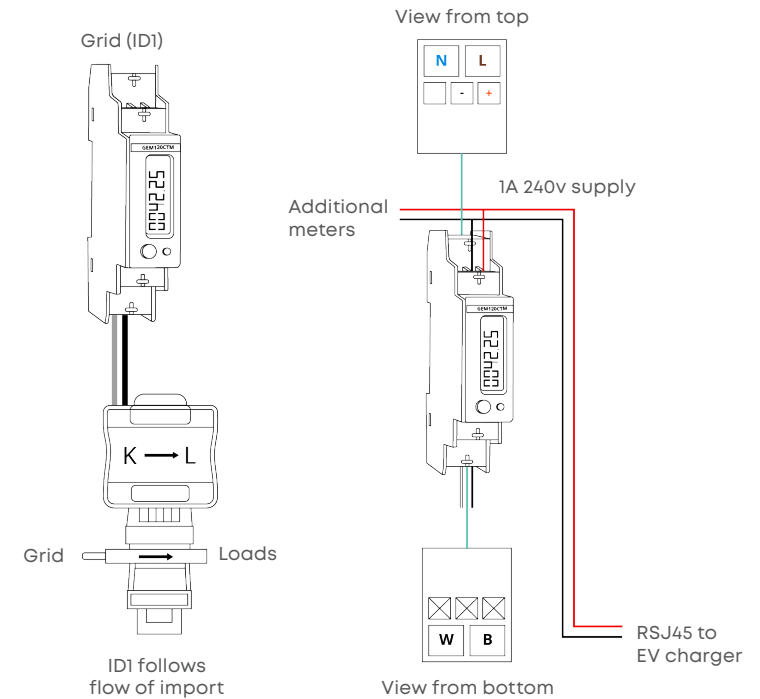

If you wish to charge from excess solar you will either need a GivEnergy Inverter (see installation configuration section), or at least 1 EM115/GEM120 (ID1) grid meter installed to monitor the import and export of the building. Every EM115/GEM120 grid meter needs a power supply or voltage reference point.

This could be a dedicated supply from a 6A MCB. This is because excess solar charging can also be achieved via cloud control OR a hard wired Gen 3 inverter.

Every EM115/GEM120 meter will need a data connection back to the EV charger's communication port. The data connection should be via twisted pair cable. (For example, Belden multi-stranded cable or Cat 5/6.)

Below is the onboarding process for a new/existing customer after the EV Charger has been physically installed.

(Ignore steps 1-4 if you are existing customer)

1. Download GivEnergy app
2. Create an account
3. Select EV Charger
4. Fill in personal details

After this is complete, it will take you to the EV Charger setup part

1. Tap start setup
2. Select configuration mode (information on each configuration mode is in the app)
3. Input DNO fuse
4. Select whether or not you are using ethernet
5. Tap confirm selection

This next page is just a walkthrough of the setup process

1. Tap start
2.
 - 2a. Scan Qr code that is on the side of the EV Charger
 - 2b. Or tap manual entry and input the information from the side of the EV charger

Next page is your home wifi information. If you selected ethernet connection in the earlier step, this part will not be present

1. Input your home wifi information (the SSID you phone is currently connected to will be automatically inputted)
2. Tap continue

This next step you will need to manually restart you EV Charger

1. Tap I have restarted my charger.
2. A pop up will appear asking if you heard a beep. If you heard the beep tap yes
3. The next page will go the the below steps automatically.
 - 3a. Connecting to EV Charger
 - 3b. Configuring EV Charger
 - 3c. Connecting back to internet
 - 3d. Registering EV Charger to your account
 - 3e. Waiting for EV Charger to come online
 - 3f. Updating EV Charger
4. Once these are complete you will be able to view your dashboard

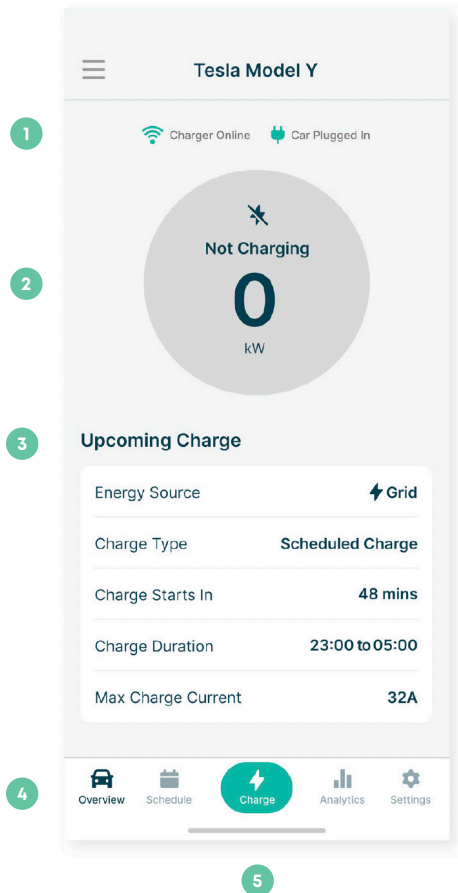

Overview Page

1. Status Indicators

A quick summary of charger connectivity and car plugged in status.

2. Status of Charge

The current charging status and immediate power draw.

3. Charging Summary

A detailed summary of current or upcoming (scheduled) charges.

4. App Navigation

Navigate between Overview, Schedules, Analytics, and settings.

5. Charge Button

This button allows you to manually start/stop charges.

App Guide

Once you have selected your mode, you will be directed to your EV charger dashboard, where you can monitor.

Dashboard Overview

- **Status of charge:** Check the current charging status
- **Active mode:** See which charging mode is currently in use
- **Summary of data:** Get a quick summary of your charger's performance and usage

Charging Modes

- **Grid:** The vehicle will charge from solar or grid power up to the maximum current charge
- **Hybrid:** The vehicle will charge at a minimum of 6A (1.4kW) using a combination of excess solar and grid power. If excess solar power exceeds 6A (1.4kW), it will be diverted into the EV
- **Solar:** The vehicle will charge only from excess solar power at a minimum of 6A (1.4kW)
- **Schedules:** You can create charging schedule slots for any start time and duration, up to 24 hours. The charger will use solar or grid power up to the maximum current charge set

Please note: Due to government regulations, there will be a randomised delay of up to 600 second (10-minute) delay for all scheduled charging slots.

Data & Graphs

- **Power graph:** View your power usage breakdown by the hour in a daily view
- **Energy graph:** See your energy consumption breakdown over time – including daily, weekly, monthly, yearly, or all-time views

With these steps and features, you can efficiently set up and use your EV charger for optimal performance and energy management.

Charging

Ensure the vehicle is turned off and that the EV charger is switched on. Plug the charging cable into the charging socket on the electric vehicle. Charging can be started by swiping the RFID card across the RFID reader on the charger unit, or via the GivEnergy app.

The EV charger will automatically stop when the electric vehicle is fully charged.

Stop Charging

To stop charging the electric vehicle, swipe the RFID card across the RFID reader on the charger unit while it is charging. The process can also be stopped by pressing 'Stop Charging' on the GivEnergy app.

Remove the charging cable from the charging socket of the electric vehicle and replace the cable back onto the unit.

RFID Cards

The EV charger comes supplied with two RFID cards that can be used to start and stop a charge. The RFID cards are online cards, meaning that they will only work if the charger is connected to the home network. To use the cards in offline mode, the card number must be added to the charger via the GivEnergy app.

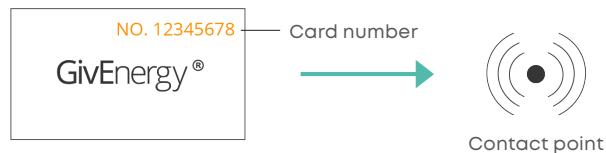

Beep Codes

When powering up the EV charger for the first time, the charger will beep a number of times before switching to normal operation.

- **1 beep** means no meter / comms detected - If you have a meter connected please check the communication cable and connections between the grid meter and the EV charger. Power down the charger and switch it back on. If the connection to the meter can be seen, you'll hear 2 beeps.
- **2 beeps** means active meter / comms detected - Okay

LED Status

Turn on the EV charger and the display will light up. The LED indicators on the display reflect the status of the charger.

Green	Charging
Green, flashing	Ready
Yellow	Communication Issue
Blue	Connected to WiFi
Blue, flashing	Not connected to WiFi
Red	Fault

Restart

1. Press the restart charger button inside the GivEnergy app
2. Turn off the AC supply to the charger, wait until the LEDs are off, and then turn on the AC supply to restart

Factory Reset

1. Power the charger down
2. Remove the decorative cover and tamper proof cover
3. Turn on the AC supply to the charger and press the tamper switch once to put in to tamper mode
4. In quick succession press the tamper switch 10 times to carry out a factory reset
5. The charger will beep and automatically restart
6. Power down the charger
7. Reinstate both covers
8. Turn on AC supply to the charger

TROUBLESHOOTING

Error Codes

11	CP Voltage Abnormal	CP Voltage out of range
12	Emergency Stop Status (Tamper Switch)	Tamper switch released
13	Under Voltage	Grid voltage too low (<161v continuous over 5 seconds)
14	Over Voltage	Grid voltage too high (>270v continuous over 5 seconds)
15	Over Temperature	Mainboard too hot (>80°C)
16	Electric Meter Fault	N/A
17	Leakage Protection	AC current leakage detected (>20mA) DC current leakage detected (>6mA)
18	Output Shortage	Charging current 10A greater than maximum output current
19	Over current	Charging current 10% greater than maximum output current
21	EV Response Timeout	N/A
22	EV Not Supported	N/A
23	Relay Sticking	AC Relay not functioning
24	Internal RCD Failure	Internal type B RCD not functioning
25	Ground Fault	Internal type B RCD not functioning
26	PEN Leakage Protection Activated	The voltage between the line and neutral conductor being greater than 253V or less than 207V. Current detected on the earth conductor

Error Code Troubleshooting - Simple

If any of the above error codes occur please try the following:

1. Visual inspection - check to ensure the EV charger is not damaged and the front cover is securely fixed
2. Check the EV charger cable and gun to ensure no damage, if plugged in to a vehicle try unplugging and replugging, check to make sure the gun is free of any water or debris
3. Try restarting the EV charger
4. Contact installer

Error Code Troubleshooting - Advanced

1. Check the AC wiring
2. Check the AC grid voltage isn't too high/low
3. Check the AC supply for earth leakage
4. Check for earth continuity
5. Check import limit is set correctly
6. Contact GivEnergy

MANUFACTURER WARRANTIES

Purpose

GivEnergy is the main supplier and manufacturer of the product. GivEnergy warrants that your product is (a) of acceptable quality and (b) does not have any latent defects.

- ✔ If you suspect something is wrong with the charger, contact GivEnergy on **01377 252 874** or email **support@givenergy.co.uk**
- ✔ If any damaged or missing parts are found, please contact GivEnergy on **01377 252 874** or email **support@givenergy.co.uk** immediately. Returns must be provided in original or equivalent packaging. The cardboard packaging is recyclable.

Product Covered



GivEnergy

Phone

UK +44 01377 252 874

NL +31 85 208 6376

Email

UK support@givenergy.co.uk

NL support@givenergy.com

SA support.sa@givenergy.com

AU martin.cobb@givenergy.com

Website

www.givenergy.com