



AC COUPLED

# EMS Hardware User Manual

GIV-EMS-V1

## SPECIFICATIONS



### SMALL AND COMPACT

#### Connect your GivEnergy Inverters

Connect your AC coupled inverters together with the EMS to give you greater capacity output and balanced battery output.

The EMS will connect to up to three AC coupled inverters and battery systems and manage them automatically. It will output the data in a simplified data stream so you can see how much total battery capacity is still available to use.

### SPECIFICATION

#### Dimensions

115H x 43D x 165W (mm)

#### Protection Class

IP20

#### Weight

1Kg

#### Operational Temperature

-20°C to 60°C

#### Operating Voltage

5VDC ( $\pm 10\%$ )

#### Relative Humidity

5~95% non-condensing

#### Max. Inverter Connections

3

#### Working Altitude

< 3000m

#### Max. Meter Connections

6

#### Self-Consumption

< 10W

#### SKU

GIV-EMS-V1

## PLANT OPERATION INTRODUCTION

### Supported Inverters

Currently, system can support AC Coupled inverters (single phase) only on Firmware. D0.291-A0.282.

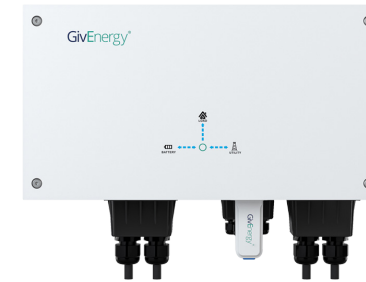

### Plant Operation

Plant EMS can support 3 AC Couple inverters and 6 EM115 meters in total. In discharge time, EMS can control all inverters discharge to the load when all batteries SOC difference within 1%. When the SOC difference between the two batteries is greater than 1%, EMS will control the high SOC battery discharge to balance the grid, if the load power greater than the inverter maximum active power, the high SOC battery will full power discharge and the lower SOC battery will balance the rest of load. In charge time, EMS will control all inverters full power charge to batteries.

## EMS Communication Port

Currently, system can support AC Coupled inverters (single phase) only on Firmware. D0.291-A0.282.

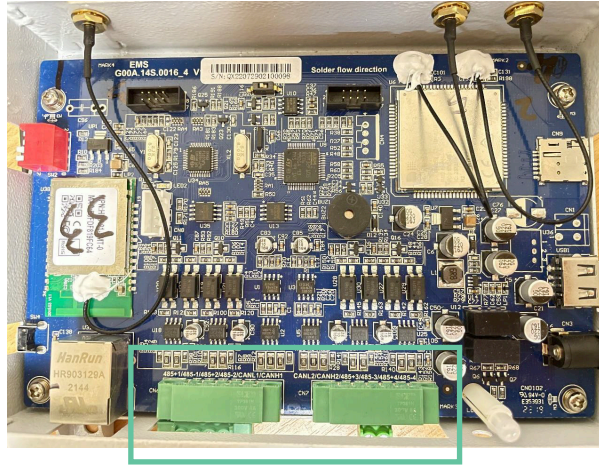

Figure 1 EMS Hardware

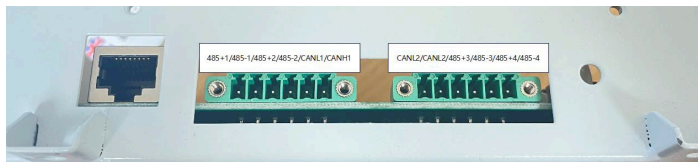

Figure 2 EMS communication port

There are 6 communication ports on EMS in figure 1 green square. For AC Couple plant system, CAN-1 port, and CAN-2 port not in use. Each RS485 port can support 1 inverter and 2 meters at the same time. RS485-1 only can support grid meter(s) and one inverter, RS485-2 only can support generation meter(s) and one inverter, RS485-3 only can support load meter(s) and one inverter. RS485-4 for future use.

## LED Identification

Currently, system can support AC Coupled inverters (single phase) only on Firmware. D0.291-A0.282.

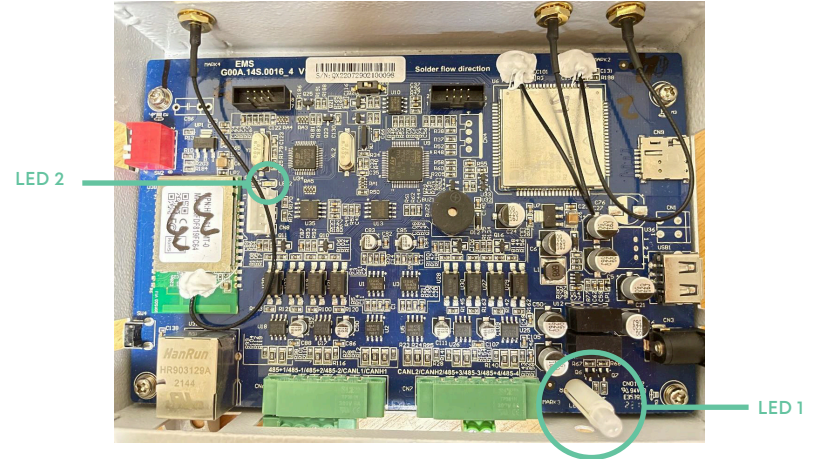

Figure 3 LED on EMS hardware

In figure 2, LED1 will show EMS status LED 2 will show communication status

Table 1 LED Indication

LED 1		LED 2	
Green and red flashing	RTC not set	Fast blue flashing	Initialising
Slow green flashing	Waiting status	Slow blue flashing	Waiting for network connection to GivEnergy server
Solid green	Normal status		
Solid red	Error status (see section 7)	Solid red	EMS is online and communication with GivEnergy sever

## ANTENNA PORT

Attaching an antenna is mandatory for using Wi-Fi. LAN mode.

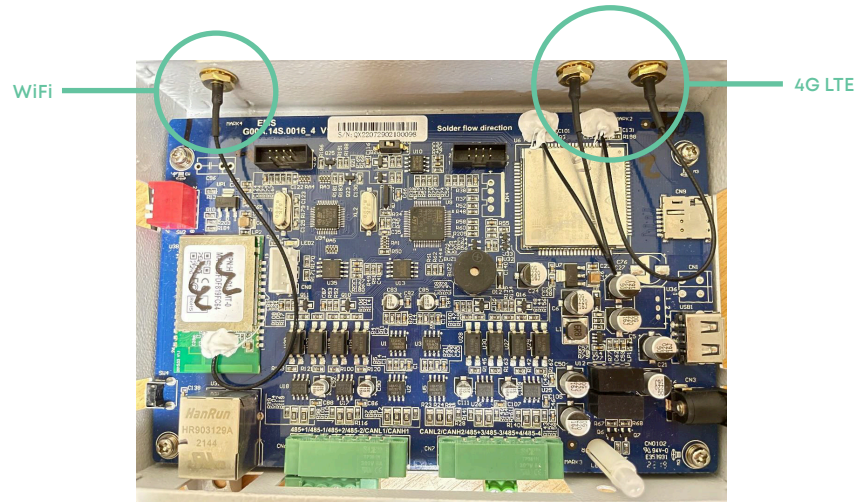

Figure 4 Antenna port

From figure 3, Antenna ports as shown Wi-Fi on the single as shown and 4G LTE on the two Antenna connection as shown in the above image

## DIP SWITCH

Dip Switch SW2

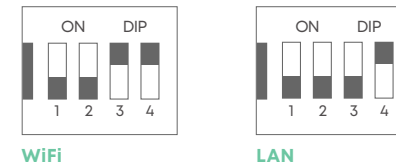

Figure 5 Dip switch for EMS

For more dip switch for SW2 information please refer to [EMS WIFI SWITCH](#)

Switch SW4 can reset the WIFI module to factory setting.



Figure 6 SW4

## SET UP COM CABLE

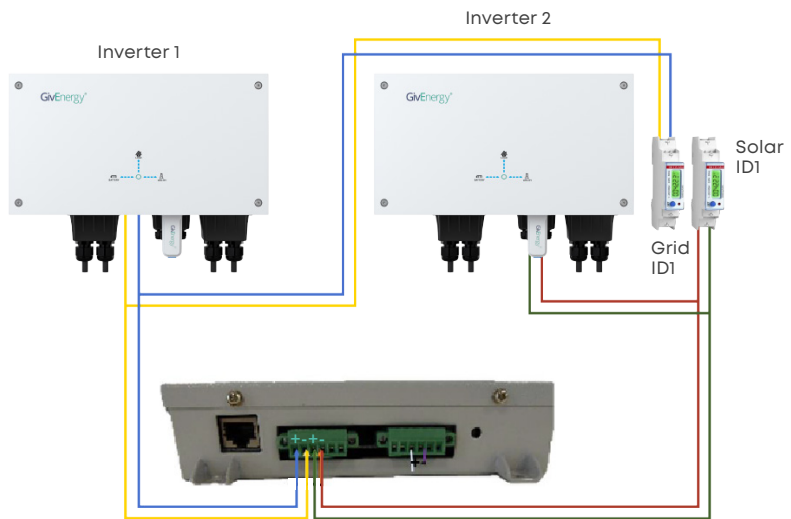

Figure 7 wiring diagram for 2 inverters with one Solar String Inverter via EMS

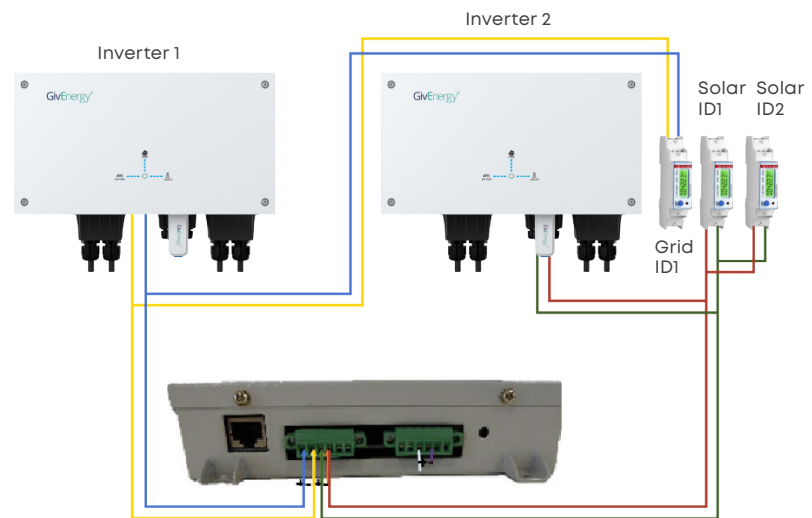

Figure 8 wiring diagram for 2 inverters with two Solar String Inverters via EMS

## SET UP COM CABLE

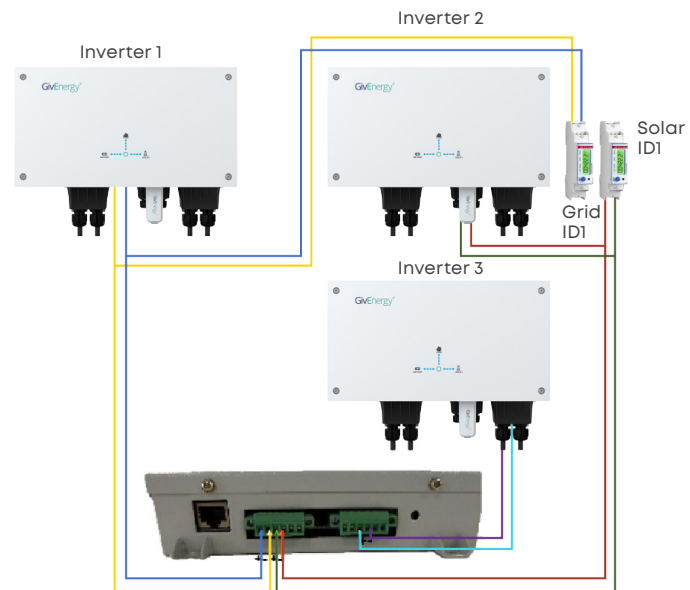

Figure 9 wiring diagram for 3 inverters with one Solar String Inverter via EMS

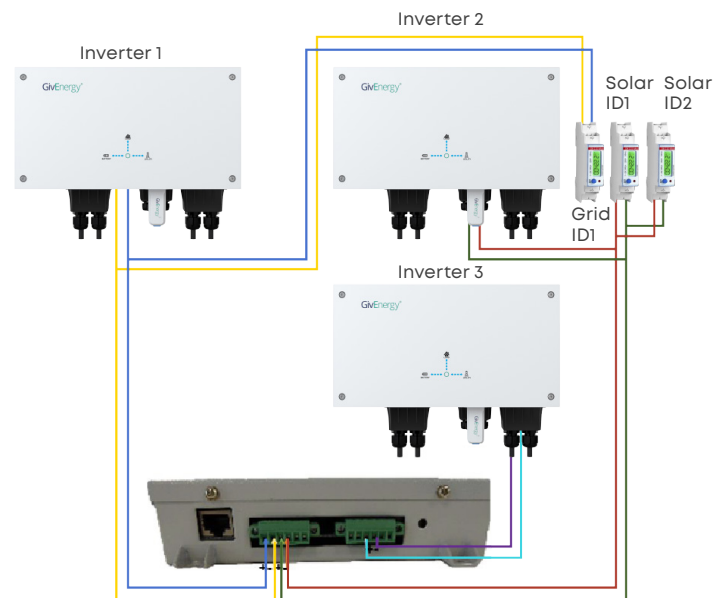

Figure 10 wiring diagram for 3 inverters with two Solar String Inverters via EMS

## SET UP COM CABLE



Any meter in RS485-1 will be considering as a grid meter. Any meter in RS485-2 will be considering as a generation meter. Any meter in RS485-3 will be considering as a load meter. If system has 3 inverters, inverter-3 can connect with RS485-3. **After setting up system remember to add the EMS to the customers account at this stage.**

## NETWORK SET UP

### WiFi Mode

1. Waiting for EMS LED-2 to slow flashing blue, connect the EMS WIFI (WIFI name is same as EMS serial number). Log in the 10.10.100.254.

2. Select **STA mode**

- Mode Selection
- AP Interface Setting
- STA Interface Setting
- Application Setting
- Device Management

### Working Mode Configuration

You may configure the Uart-WIFI module wifi mode and data transfer mode.

AP Mode:  
Access Point

STA Mode:  
Station Mode

Data Transfer Mode:

3. Search **WIFI name**

- Mode Selection
- AP Interface Setting
- STA Interface Setting
- Application Setting
- Device Management

### STA Interface Setting

You could configure STA interface parameters here.

STA Interface Parameters	
AP's SSID	BTB-P6CGSX <input type="button" value="Search..."/>
MAC Address (Optional)	<input type="text"/>
Security Mode	WPA2PSK
Encryption Type	AES

4. Enter the **WiFi password**, then **click apply**

- Mode Selection
- AP Interface Setting
- **STA Interface Setting**
- Application Setting
- Device Management

### STA Interface Setting

You could configure STA interface parameters here.

STA Interface Parameters	
AP's SSID	BTB-P6CGSX <input type="text" value="Search..."/>
MAC Address (Optional)	<input type="text"/>
Security Mode	WPA2PSK ▾
Encryption Type	AES ▾
Pass Phrase	<input type="password"/>

WAN Connection Type:

DHCP Mode	
Hostname(Optional)	HF-A21

5. Restart the WIFI module

- Mode Selection
- AP Interface Setting
- STA Interface Setting
- Application Setting
- **Device Management**

### Device Management

5.02T.04  
You may configure administrator account and password, load default setting or update firmware.

Administrator Settings	
Account	admin
Password	admin

Restart Module	
Restart Module	<input type="button" value="Restart"/>

Load Factory Defaults	
Load Default Button	<input type="button" value="Load Default"/>

Update Firmware	
Location:	<input type="button" value="选择文件"/> 未选择任何文件

1. Waiting for EMS LED-2 to flashing blue, connect the EMS WIFI (WIFI name is same as EMS serial number). Log in the 10.10.100.254
2. Apply AP mode

- Mode Selection
- **AP Interface Setting**
- STA Interface Setting
- Application Setting
- Device Management

### STA Interface Setting

You could configure STA interface parameters here.

STA Interface Parameters	
AP's SSID	BTB-P6CGSX <input type="text" value="Search..."/>
MAC Address (Optional)	<input type="text"/>
Security Mode	WPA2PSK ▾
Encryption Type	AES ▾
Pass Phrase	<input type="password"/>

WAN Connection Type:

DHCP Mode	
Hostname(Optional)	HF-A21

3. Device can automatically get an **IP address using DHCP**
4. If device cannot get an IP address automatically, refer **static IP setting**
5. Restart device

- Mode Selection
- AP Interface Setting
- STA Interface Setting
- Application Setting
- **Device Management**

### Device Management

5.02T.04  
You may configure administrator account and password, load default setting or update firmware.

Administrator Settings	
Account	admin
Password	admin

Restart Module	
Restart Module	<input type="button" value="Restart"/>

Load Factory Defaults	
Load Default Button	<input type="button" value="Load Default"/>

Update Firmware	
Location:	<input type="button" value="选择文件"/> 未选择任何文件

EMS Portal

EMS data page will show the system load value, total battery power, grid power and battery SOC.

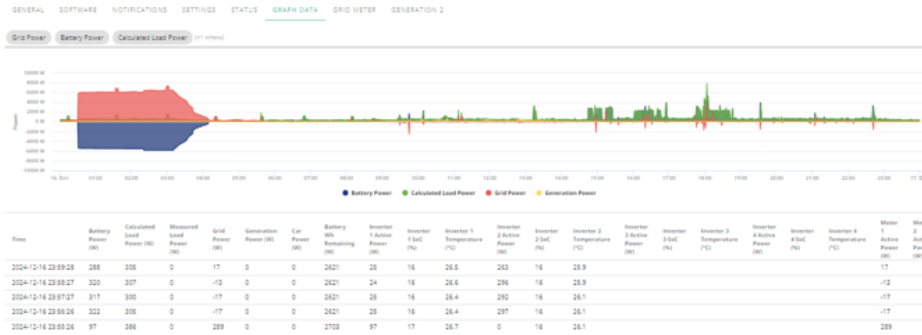

Figure 11 EMS Data

On inverter cloud page, we can get the battery cells data (Figure 12 Battery cell information), inverter status, individual inverter active power, and load value for current inverter (Figure 13 Inverter information).

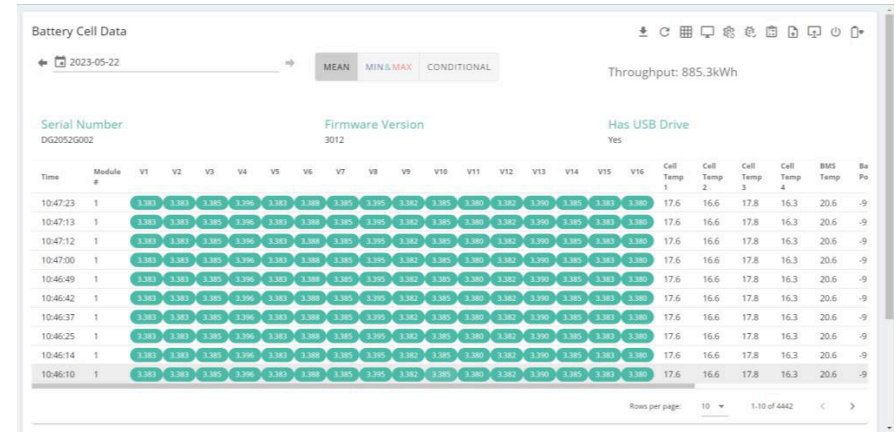

Figure 12 Battery cell information

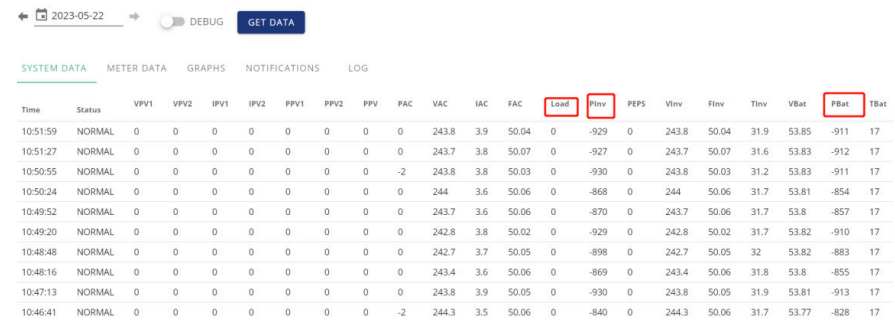

Figure 13 Inverter information

## REMOTE CONTROL SETTINGS

### Inverter Remote Control Settings

Make these changes before changing the firmware.

1. Set each inverter Charge time to default value 00:00-23:59 or 00:00-24:00

Charge 1 Settings

AC Charge 1 Start Time  AC Charge 1 End Time

2. Set discharge time 00:00-24:00 or 00:00-23:59

Charge 1 Settings

DC Discharge 1 Start Time  DC Discharge 1 End Time

3. Set inverter meter to CT

Meters/CT

READ CATEGORY

Enable Meters  CT  DC Direction

4. Set inverter Eco OFF, Ac Charge Enabled OFF, Enable DC Discharge to OFF

Enable Eco Mode  AC Charge Enable

Enable DC Discharge

## INVERTER FIRMWARE UPDATE

Update inverter ARM to 282 version, update inverter DSP to 291 version or DSP289 version from the firmware update page doing the ARM then the DSP and then restart the inverter.

### Inverter Firmware

Type: WiFi Module ARM  
Version: 102  
Latest: 102

Type: Inverter ARM  
Version: 282  
Latest: 282

Type: Battery ARM (Gen 1)  
Version: 3017  
Latest: 3017

### Manual Firmware Upgrade

SELECT FILE UPLOAD FILE

Firmware Type  
Inverter ARM

Select a file  
282 - STABLE (PLANT EMS) (106.89 KB)

UPDATE FIRMWARE

### Inverter Firmware

Type: WiFi Module ARM  
Version: 102  
Latest: 102

Type: Inverter ARM  
Version: 282  
Latest: 282

Type: Battery ARM (Gen 1)  
Version: 3017  
Latest: 3017

### Manual Firmware Upgrade

SELECT FILE UPLOAD FILE

Firmware Type  
Inverter DSP

Select a file  
291 - STABLE (PLANT EMS) (128 KB)

UPDATE FIRMWARE

## EMS TIME SETTING

### Set RTC by Pressing Send then Restart EMS

#### Time & Date

Set Date and Time ---	SEND
System Time Day ---	12
System Time Second ---	19

### Set Export Limit in Watt

#### Grid Settings

Grid Export Power Limit ---	8000	W
--------------------------------	------	---

Remember to restart the EMS unit after setting the real time clock, setting the clock just requires you to press the set date and time send button.

## EMS REMOTE CONTROL SETTINGS

### Off Peak Charge Times

GENERAL SOFTWARE NOTIFICATIONS **SETTINGS** STATUS GRAPH DATA GRID METER GENERATION 2 METER 4

TIMED CHARGE This mode will trigger your battery to charge at the times you specify

TIMED DISCHARGE

TIMED EXPORT

RESET TO DEFAULTS

PLANT ENABLE

CLEAR TIMES

Slot 1  
Start Time 00:30 End Time 07:30 Charge To 100%

Show 2 Other Slots

Slot 2  
Start Time 00:00 End Time 00:00 Charge To 100%

Slot 3  
Start Time 00:00 End Time 00:00 Charge To 100%

SUBMIT

### Enable Plant Mode

GENERAL SOFTWARE NOTIFICATIONS **SETTINGS** STATUS GRAPH DATA GRID METER GENERATION 2 METER 4

TIMED CHARGE This mode will enable the plant to minimise import and export from the grid

TIMED DISCHARGE

TIMED EXPORT

RESET TO DEFAULTS

PLANT ENABLE **Enabled**

SUBMIT

## Set Discharge Time

GENERAL SOFTWARE NOTIFICATIONS **SETTINGS** STATUS GRAPH DATA GRID METER GENERATION 2 METER 4

TIMED CHARGE **This mode will trigger your battery to cover your home's electric demand only at the times you specify**

**TIMED DISCHARGE**

TIMED EXPORT

RESET TO DEFAULTS

PLANT ENABLE

**Slot 1**

Start Time 00:00 End Time 00:30

CLEAR TIMES

Discharge To 10%

Show 2 Other Slots

**Slot 2**

Start Time 07:30 End Time 23:59

CLEAR TIMES

Discharge To 10%

**Slot 3**

Start Time 00:00 End Time 00:00

Discharge To 10%

SUBMIT

## Set Timed Export

GENERAL SOFTWARE NOTIFICATIONS **SETTINGS** STATUS GRAPH DATA GRID METER GENERATION 2 METER 4

TIMED CHARGE

TIMED DISCHARGE

**TIMED EXPORT** **This mode will trigger your battery to discharge at its max power at the times you specify**

RESET TO DEFAULTS

PLANT ENABLE

**Slot 1**

Start Time 00:00 End Time 00:00

Export To 4%

Show 2 Other Slots

**Slot 2**

Start Time 00:00 End Time 00:00

Export To 4%

**Slot 3**

Start Time 00:00 End Time 00:00

Export To 4%

SUBMIT

## Error Messages

Table 2 Error Code Table

Code	Type	Description	Action
0x0000	None	No error	None
0x0001	Warning	Generation meter communication failed	Check meter
0x0002	Warning	Inverter lost. Plant still operational but running on a reduced number of inverters	Check inverter, is it offline, check connection
0x8000	Error	RTC time invalid	Set EMS Time Date
0x8001	Error	Grid meter communication failed	Check connection
0x8002	Error	All inverters lost	Check wiring
0x8003	Error	Configuration mismatch. During initialisation the number of meters and inverters detected did not match the configuration.	Ensure number of meters or /and inverters match in EMS settings

## TROUBLESHOOTING

Trouble	Resolution	Note
LED	LED 1 flashing red and green	Set RTC on the portal
	LED 1 flashing red	Refer to section 5
	LED 1 flashing green	
	LED 2 fast flashing blue	103 firmware lost
	LED 2 slowly flashing blue	WIFI password wrong Internet signal weak
Inverter	Inverter error: Grid Port Monitor Communication Fail	Check the com cable between inverter and EMS
	Electricity Meter Com Fail	Disable meter on inverter settings (Change meter to CT)
	Inverter cannot discharge to load	Check inverter discharge time setting and charge time setting (Section 6.1)
	EMS cannot update FW version after updating on portal	Restart failed when finish update
	EMS cannot detect multiple inverters	Check 485 wiring, ensure polarity is correct ensure the wires are connected correctly at the Meter, inverter, EMS

## ADDITIONAL INFORMATION

The EMS requires a 240v power source for the included 240/5v adapter plug that is included.

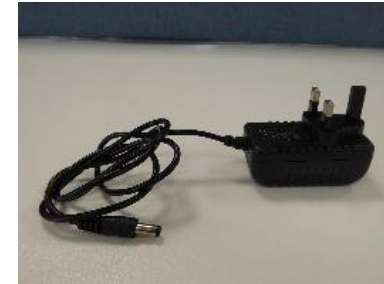

Also included is an external Wi-Fi antenna.



The dimensions of the EMS are W165mm x L115mm x D43mm.

**What meters will the EMS work with?**

The system only works with EM115 and OB115 and Gem 120 meters at this moment in time, there is a guide published on how to reprogram the ID numbers of Modbus meters on the Beta EMS installers Page.

**Why doesn't my EMS read the Inverter or the meters**

You may have to restart the EMS after several times to pick up all the meters especially if you have had to make changes to the Inverters because you forgot a setting or changed a meter.

Check the Wiring and ensure that the polarity is correct, ensure you have continuity and that the wiring is correct.

It takes up to 4 minutes for the EMS to get its initial values from the inverters and meters, please do not keep restarting the EMS it won't get any quicker in this initial data gathering phase.

On each 485 port the first meter should be an ID1 meter even for PV meters, ID2 meters will be the second meter each 485 Port can only support two meters.

Port 1	Port 2	Port 3	Port 4	Can-bus 1 & Can-bus 2
Inverter 1	Inverter 2	Inverter 3	Not used at this time.	Not used at this time.
Grid Meter 1	PV Meter 1	Load Meter 1		
Grid Meter 2	PV Meter 2	Load Meter 2		

If you have been previously running Beta Firmware a grid reset will be required to clear any unused registers, then go through the setting as detailed in this document and then restart the inverter again.

Check the EM115 meter it should have approx. 3.6 to 10 volts output on the 485 Mod-bus, we have seen some that are 0 volts which means the EM115 may be faulty,

GivEnergy is the main supplier and manufacturer of the product. GivEnergy warrants that your product is (a) of acceptable quality and (b) does not have any latent defects.

- ✔ If you suspect something is wrong with the battery, contact GivEnergy on **01377 252 874** or email **support@givenergy.co.uk**
- ✔ If any damaged or missing parts are found, please contact GivEnergy on **01377 252 874** or email **support@givenergy.co.uk** immediately. Returns must be provided in original or equivalent packaging. The cardboard packaging is recyclable.

**Product Covered**



# GivEnergy

---

## Phone

UK +44 01377 252 874

NL +31 85 208 6376

## Email

UK [support@givenergy.co.uk](mailto:support@givenergy.co.uk)

NL [support@givenergy.com](mailto:support@givenergy.com)

SA [support.sa@givenergy.com](mailto:support.sa@givenergy.com)

AU [martin.cobb@givenergy.com](mailto:martin.cobb@givenergy.com)

## Website

[www.givenergy.com](http://www.givenergy.com)