



INSTALLATION GUIDE

All in One, Giv-Gateway User Manual

GIV-AIO-13.5 / GIV-AIO-13.5-3.6
GIV-AIO-GW1

CONTENTS

INTRODUCTION

General Introduction	4
System Diagram	5

ALL IN ONE INSTALLATION

All in One Specifications	7
All in One Box Contents	8
All in One Components	9
All in One Unboxing	10
Installation Instructions	11
Safety Instructions	12
Clearance and Maintenance	13
All in One Step-by-Step Installation	14
All in One Parallel Mode Instructions	16
All in One Connections Overview	20
All in One AC Utility grid Connection	21
All in One Comms Connection with Giv-Gateway	22
All in One Comms Connection without Giv-Gateway	23
GEM120CT Overview and Instructions	24

GIV-GATEWAY INSTALLATION

Giv-Gateway Specifications	26
Giv-Gateway Box Contents	27
Isolating the Main Supply to the Property	28
Giv-Gateway Components	29
Clearance and Maintenance	30
Giv-Gateway Step-by-Step Installation	31
Connections Overview	32
Giv-Gateway AC Utility Grid Connection	33
Giv-Gateway Wiring Connections	34
All in One Neutral Continuity	35
Giv-Gateway Communication Connections	36
Connecting All in One to Giv-Gateway	37

CONTENTS

CONFIGURATION

Setting Up Monitoring	38
Enabling DRM Control	39
Adjust Power Quality Response Mode Setpoints	41
View Inverter Firmware and Settings	44
Generation Control & Export Control Settings	50
WiFi Guide	51
Commissioning and Decommissioning a System	55

FUNDAMENTALS

Understanding your All in One	57
Understanding your Giv-Gateway	58
All in One Installation with Giv-Gateway	59
All in One Installation without Giv-Gateway	60
Work Modes	61
Manufacturer Warranties	62

Introduction

All information contained in this booklet refers to the installation and maintenance of GivEnergy's All in One and Giv-Gateway. Please retain this manual for future reference.

Legal Disclaimer: This document is the property of GivEnergy, reproduction is prohibited.

Installation Requirements

Installation of the GivEnergy All in One and Giv-Gateway must be carried out by a **GivEnergy Approved Installer**, in accordance with local wiring regulations, and by a registered and qualified electrician. installation.

Unit Information

The All in One contains a bidirectional inverter and a 13.5kWh lithium iron phosphate battery. When used with our Giv-Gateway, the system can provide whole home backup when a power outage occurs. The system can charge from the grid when prices are cheaper, and export stored generation when prices are at their peak. The Giv-Gateway interface features connections for a PV inverter, EV charger, grid and home storage battery.

Storing the All in One and Giv-Gateway

The unit must be stored in its original packaging at temperatures between -40°C - 70°C .

Do not stack more than 5 units on top of each other.

Packaging Contents

When unpacking, please check the following:

- ✔ There are no missing accessories from the packaging list
- ✔ The model and specification of the All in One and Giv-Gateway's nameplate match the order specifications
- ✔ Ensure the packaging and product are free from any damage

If any damaged or missing parts are found, please contact GivEnergy on **01377 252 874** or email **support@givenergy.co.uk** immediately. Returns must be provided in original or equivalent packaging. The cardboard packaging is recyclable.

With Giv-Gateway

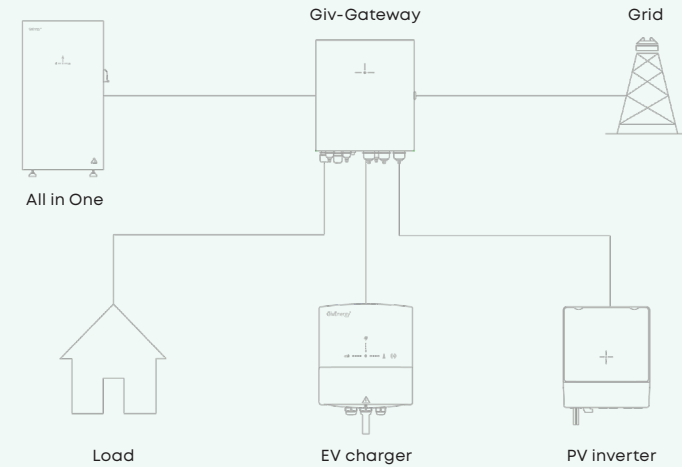

Without Giv-Gateway

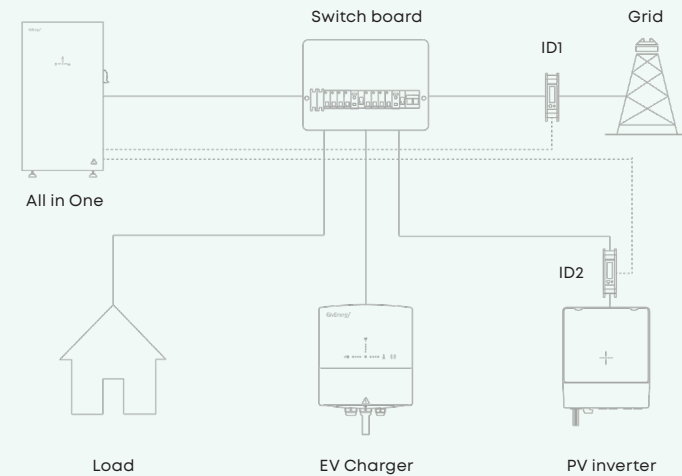



ROBUST AND FLEXIBLE

A great addition to any smart home

Primarily working as an on grid system, the All in One can deliver 7.2kW of peak power* into the home on top of any solar generation.

Complete with a substantial 13.5kWh usable battery pack that stores excess generation. Featuring a modular design comprising 4 removable battery packs, allowing for ease of handling and installation.

SPECIFICATION

Dimensions

1100H x 280D x 600W (mm)

Warranty

12 years

Weight

173.7Kg

Connectivity

WiFi, LAN and 4G

Noise Emission (Typical)

<30dB

Operating Temperature

-10°C - 50°C

Ingress Protection Rating

IP65

Depth of Discharge

100%

Environmental Category

Suitable for outdoor and indoor installations.

AC Max. Output Rating

3.6kW / 16 A Peak/continuous
7.2kW / 32A Peak/ 6kW / 27A continuous

Pollution Degree

2 (Giv-Gateway),
3 (All in One)

Model numbers

GIV-AIO-AC-13.5-3.6 + Giv-Gateway
GIV-AIO-AC-13.5 + Giv-Gateway
GIV-AIO-AC-13.5-3.6
GIV-AIO-AC-13.5

All in One Installation

ALL IN ONE BOX CONTENTS

Item	Item Name	Qty
A	All in One Unit	1
B	Bracket	2
C	Expansion Bolt	4
D	WiFi Antenna	1
E	Spirit Level	1

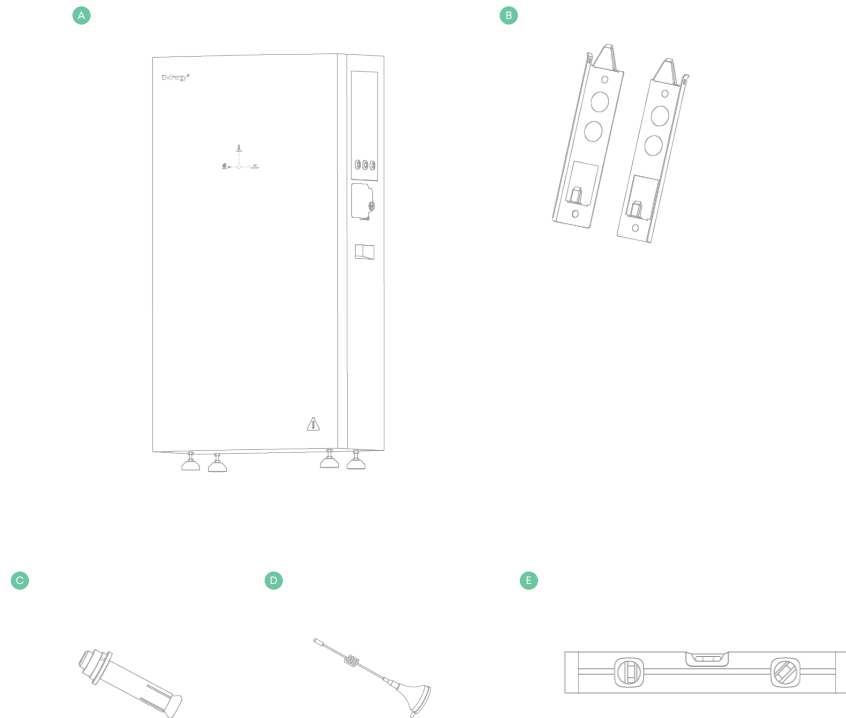

ALL IN ONE COMPONENTS

Item	Item Name
A	Power Flow Indicator
B	AC Supply Terminals
C	WiFi Antenna
D	DC Circuit Breaker
E	On / Off Switch
F	Cable Entry Point

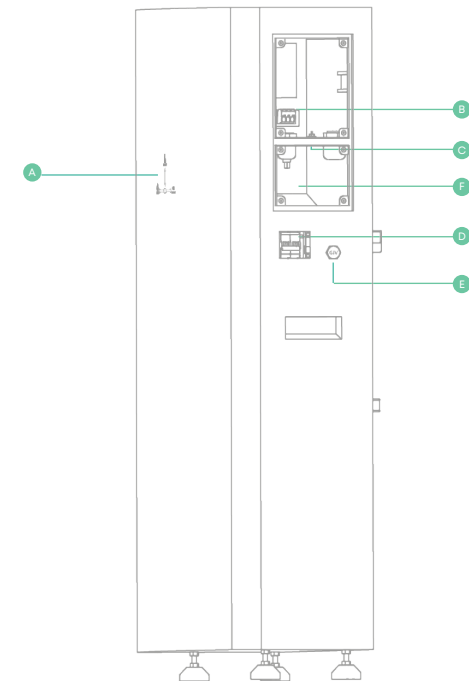

ALL IN ONE UNBOXING

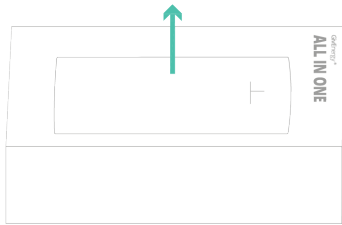

1. Remove top cover from the wooden crate, ensuring to wear gloves and taking care when bending the metal tabs.



3. Remove the foam and then the front cover of the All in One

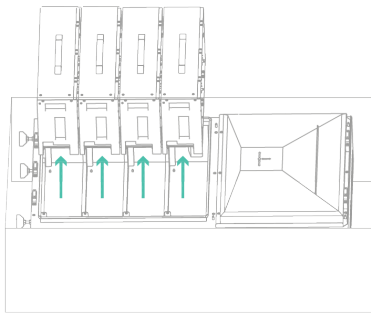

5. Remove the battery packs, leave to one side

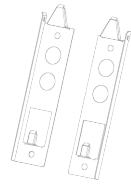

2. Remove the All in One brackets, template, and accessories and place to one side

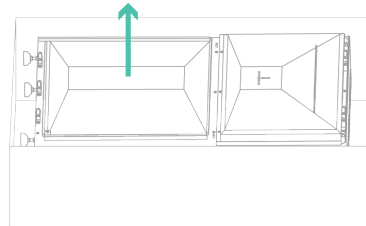

4. Remove bottom waterproof cover of the All in One

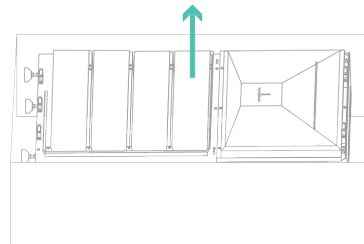

6. Remove All in One case from wooden crate (2 person lift)

INSTALLATION INSTRUCTIONS

Dos



The system must be installed in an easily accessible location, the status display must be visible and not obstructed



Please ensure that the wall to be mounted on is sufficient enough to hold the weight of the All in One and Giv-Gateway (if fitted)



The system must be installed in a well ventilated area, the ambient temperature should be below 40°C to ensure optimal operation



The system must be installed vertically with connections always positioned at the bottom, never install horizontally, and avoid tilting the unit



The system must be installed under a canopy if installing externally unless fully shaded



The feet of the All in One are designed to be above the frost-line at a minimum of 50mm



You must comply with local battery and inverter installation guidelines and regulations

Don'ts



Do not use the system if the temperature exceeds 45°C



Do not install in direct sunlight or near water sources



Do not use the equipment if there are any deformities, such as bulging or leakages



Do not puncture the equipment



Do not throw the equipment or use forceful impact



Do not attempt to repair the battery yourself (please call your Approved Installer)

SAFETY INSTRUCTIONS

Safety Instructions

Extra care and attention must be taken when installing and maintaining any GivEnergy equipment. The system is capable of retaining a high voltage, even when disconnected.

- If you suspect something is wrong with the system, contact GivEnergy on **01377 252 874** or email **support@givenergy.co.uk**
- If any damaged or missing parts are found, please contact GivEnergy on **01377 252 874** or email **support@givenergy.co.uk** immediately. Returns must be provided in original or equivalent packaging, for safe transport, please refer to our UN38.3 certificate
- All electrical installations must be carried out by a qualified and registered electrician and in accordance with the local Wiring Regulations and other relevant safety legislation
- During operation, the heat sink may become hot. Do not touch the heat sink at the sides, or the top of the inverter when in operation
- The system is designed to be connected to the grid; connecting your inverter to a generator or other power source can result in damage to the inverter or external devices and may invalidate your warranty
- All GivEnergy equipment must be installed by a **GivEnergy Approved Installer**
- Ensure all components are attached securely
- Ensure the All in One and Giv-Gateway are always fixed to the wall using the mounting bracket
- Any errors are shown with a red LED, for full descriptions please refer to the GivEnergy monitoring portal

CLEARANCE AND MAINTENANCE

Space Clearance

There must be adequate clearance around the All in One to allow for heat dissipation. The diagram below illustrates the space required around the system.



Maintenance

When maintaining and cleaning the All in One, the **whole system must be powered down**. Please refrain from using cleaning products on the surface of the All in One. Ensure that the heat sink is free from blockage to allow proper air flow. Check that no cables, isolation points, or the casing itself are physically damaged.

To ensure your All in One operates optimally at all times, annual maintenance checks need to be carried out. Check for visible damage or discolouration of the switch, and that the cables are intact. Please ensure that the top of the All in One is not obstructed in any way.

ALL IN ONE STEP-BY-STEP INSTALLATION

Step 1: Place the wall mounting template horizontally onto the wall and mark the position of the bracket holes. Drill 4 holes at the marked positions, at least 75mm deep.

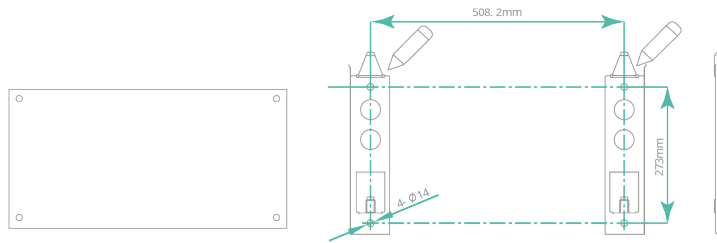

Step 2: Fix the mounting bracket to the wall using the expansion bolts or suitable fixings.
Please note: The brackets are sided.

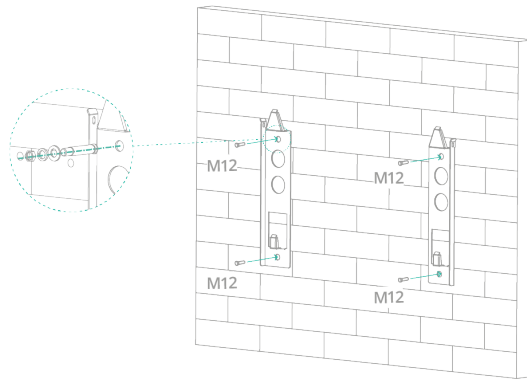

ALL IN ONE STEP-BY-STEP INSTALLATION

Step 3: Mount the All in One onto the mounting bracket. Adjust the height of the supporting feet to ensure the unit is level and attach the securing screws to the brackets, ensuring the weight is on the feet, not the brackets.

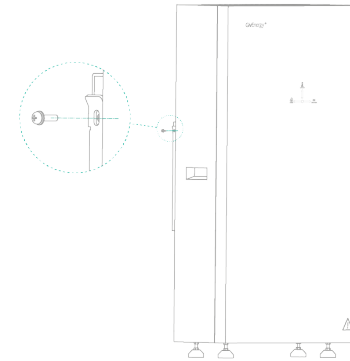

Step 4: Re-insert the battery modules into the shelves of the All in One battery compartment. Secure the battery modules using the fixings provided. Re-attach waterproof cover.

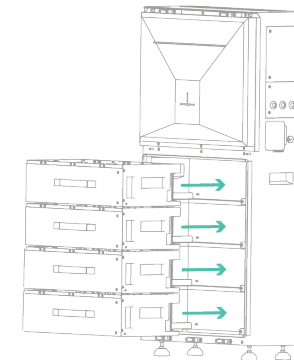

Step 5: Reverse steps 1 & 2 and use the screws / fixings originally removed.

ALL IN ONE PARALLEL MODE INSTRUCTIONS

Description

The new parallel function will allow up to 3 x AIO 6kw inverter/battery units to be connected to the same gateway. Providing up to 18kw of power and 40.5kWh of storage in one single virtual system. This is all managed by the Gateway itself, including setup & user operations. All In One parallel support all the same functions as a single unit, including whole home backup.

System Overview

The system is connected as follows:- The AC supplies of each AIO are connected into the Gateway via their own 6mm cable and individual RCBO. The Communications cable from the Gateway connected to AIO1 (Master). From AIO1 there is 2 x RJ45 cables to AIO2 and if a 3rd unit fitted, a further 2 from AIO2 to AIO3.

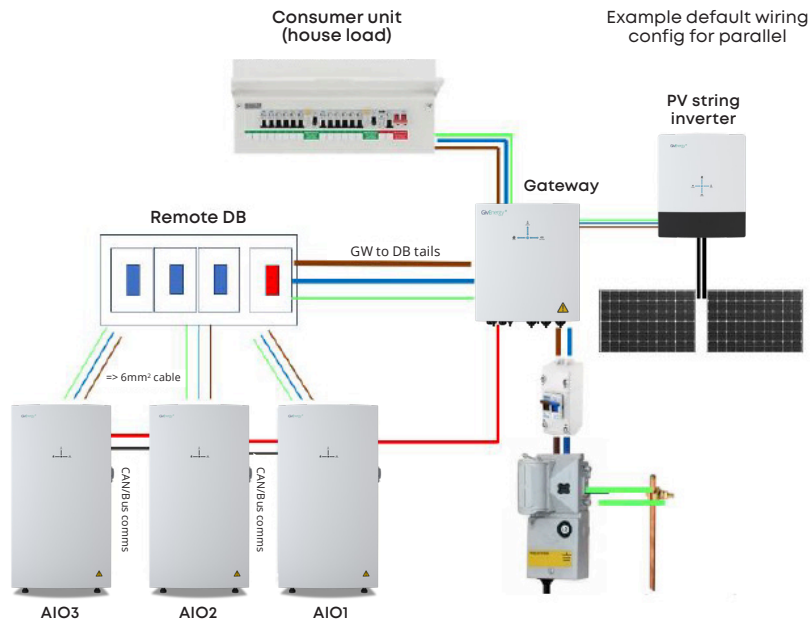

ALL IN ONE STEP-BY-STEP INSTALLATION

Electrical Connections

There are 2 methods of connecting the additional inverters to the gateway. You may use either method, one may be more suited than the other, depending on installation scenario and location.

Option 1 – Use Gateway External Tails Connection (Preferred)

Power the Installation down and isolate from the mains supply. Connect tails to the rear terminal block of the gateway and bring them out of the gateway to a separate mini consumer unit, located near the AIOs. In this new remote CU, you can install the required circuit protection for the All In One inverter/battery units to be installed. The integral RCD/MCB in the gateway is now no longer in use. Circuit protection in the remote DB must be double pole, bi-directional, type A and rated C32. Example ABB DS201C32A30.

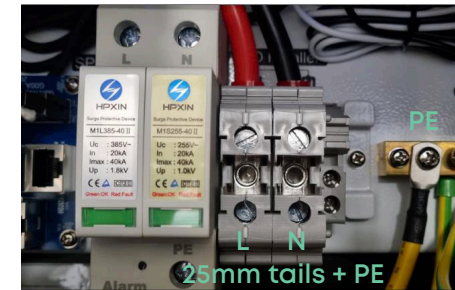

Option 2 – Integral into Gateway Housing (Alternative if AIOs are located with the GW)

Power the installation down and isolate from the mains supply. Remove the supplied RCD/MCB unit(s) and replace with 2 or 4 Bi-Directional RCBOs with a rating of C32. Example being ABB DS201C32A30, 32A rated and 30mA TypeA.

Additional Busbar tails will be required and should be of at least 6mm size and 200mm in length. Terminated in M6 Eyelets on one end. These tails should be secured to the Busbar spare ways using M6x14mm Flange Bolts, tightened to 2.5Nm. Example here Shows 2 x DS201C32A30 correctly in the Gateway to support 2 x AIO units. Leaving the existing PV RCD/MCB in place.

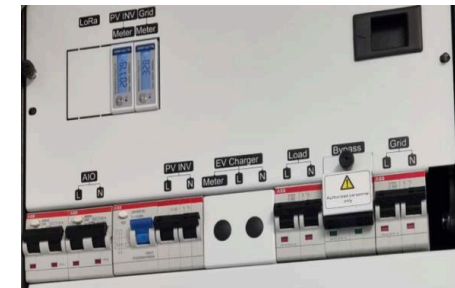

ALL IN ONE PARALLEL MODE INSTRUCTIONS

Firmware Requirements

Load all All In One units with at least D612-A612 firmware. Ensure the AIO is rebooted, and firmware is validated correct before connecting up the communications cabling, to ensure the inverter are parallel enabled. Firmware will be loaded on commissioning, manually via USB locally, or via USB-A to USB-A cable locally. Locally is the preferred option.

Load the Gateway with at least v10 firmware, which support parallel and LoRa. Until the Gateway is at version 10 or higher, **it will not communicate with the multiple inverters and may generate an error. Therefore ensure the gateway is at the correct release before proceeding.**

Also update the WirelessModule.bin file. So the full data set is sent to portal.

Communication Connections

Connect a fully wired RJ45 cable from the Gateway to AIO1, this may already be present, if converting from a single installation.

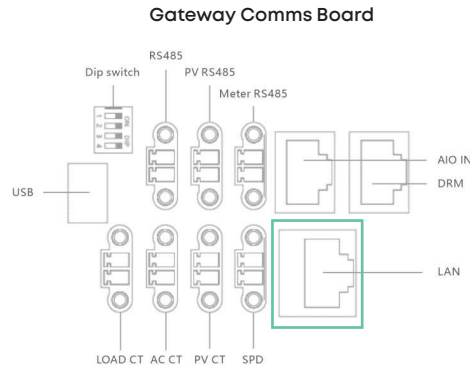

Connect 2 x RJ45 cables between AIO1 and AIO2

1. AIO1 GW-Out to AIO2 GW-In (Gateway Comms)
2. AIO1 Parallel-Out to AIO2 Parallel-In (Sync Comms)
3. Repeat between AIO2 and AIO3 if a 3rd unit is required.

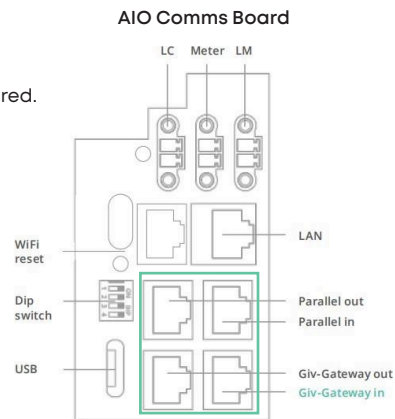

ALL IN ONE PARALLEL MODE INSTRUCTIONS

Setup & Configuration (If Existing Commission Exists, Delete It, Create New)

All configuration is done at the Gateway for a parallel installation. Parallel Commissioning will setup the gateway in the Configure Inverter step. This will reboot both inverters simultaneously in the process. This step puts the AIOs in parallel mode and sets their grid parameters.

All devices are required to be on the same customer account, ie. 2 or 3 x AIO and 1 x Gateway. This will configure the portal and App to point any configuration at the gateway, instead of the AIOs themselves. Add all devices, before proceeding with commissioning. All other settings and configuration is the same as a single AIO.



This will restrict total combined Inverter power, default is 18kw, but could be set at 6kw, so despite having 3 x AIOs, their combined generation capacity cannot exceed 6kw.

ALL IN ONE CONNECTIONS OVERVIEW

Item	Item Name
A	Communication / Network Ports
B	AC Supply

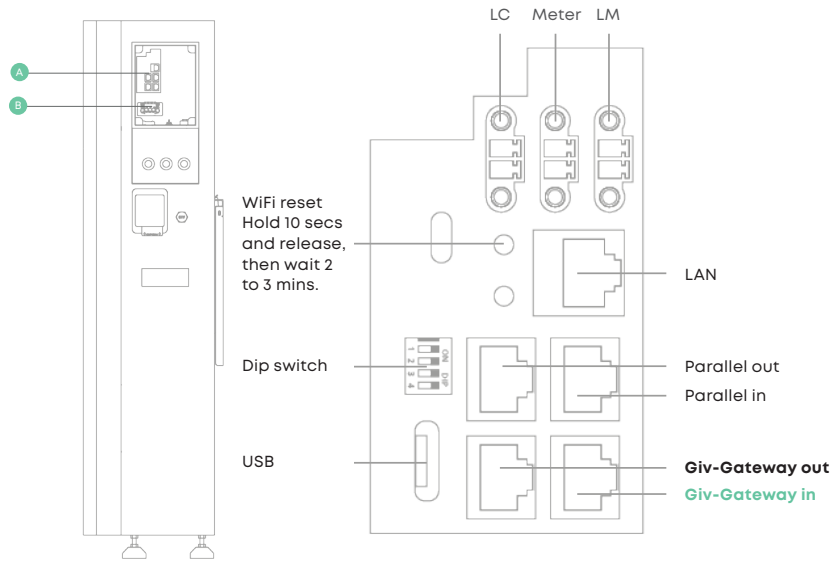

All in One Communication / Network Ports



WiFi

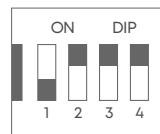

LAN

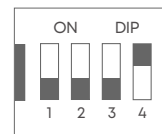

USB (Dongle) Mode

ALL IN ONE AC UTILITY GRID CONNECTION

If installing using the Giv-Gateway, the RCD is already included. If being installed without the Giv-Gateway, the installer will need to source their own RCD / protection device and ensure that the current rating is suitable for the installation.

Cable size requirements are dependent on the country of installation, cable run length, and mix. current of the product.

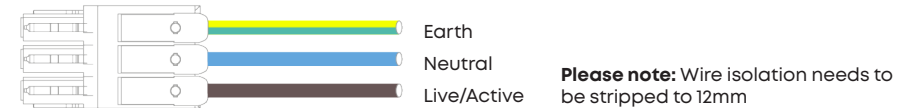

Both side and rear cable entry points are provided. If using rear entry point, please ensure the cable is installed prior to fitting the All in One. The AC supply cable should enter through one of the waterproof glands, and pass through the cable entry chamber (labelled below), and connected into the AC supply plug.

Strip the outer insulation to 12mm in length of bare copper and connect them to the plug (instructions are on the side of the plug).

The recommended maximum cable length should not exceed 50m as the resistance of the cable will consume inverter output power and reduce the inverter efficiency.

The main earth connection in the AC connection plug bonds to the chassis and external metallic parts when inserted into the AC connection port.

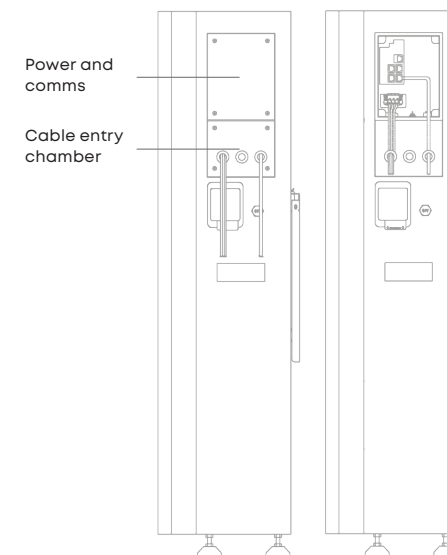

The AIO/Giv-Gateway is a Class I protective product, so its enclosure is to be grounded to ensure personal safety. This is achieved by connecting the earthing (PE) wire from grid to the PE busbar in Giv-Gateway and then/or in case of no Giv-Gateway, the AIO's PE terminal on its AC terminal block. The PE terminal on AIO and Giv-Gateway has direct and good contact with their respective metal enclosure.

Type A RCD with 30mA tripping setting is already integrated in Giv-Gateway. For standalone version AIO, a Type A RCD with 30mA tripping current is recommended to be used.

ALL IN ONE COMMS CONNECTION WITH GIV-GATEWAY

Single All In One Installation

To install a single All in One, connect the communication wire to the socket D in the wiring compartment of the All in One.

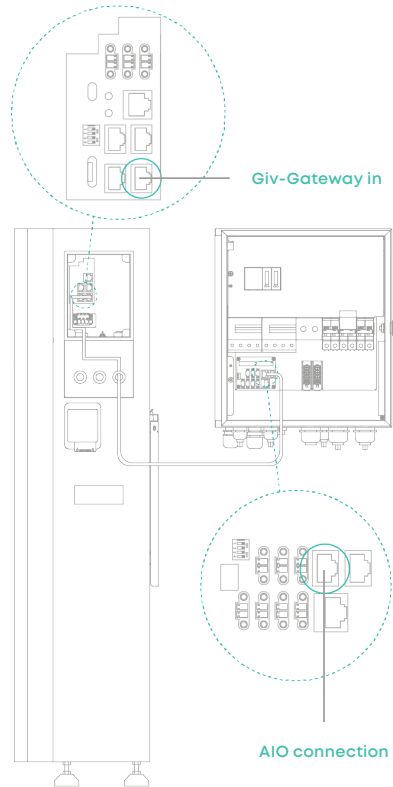
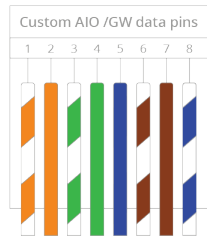
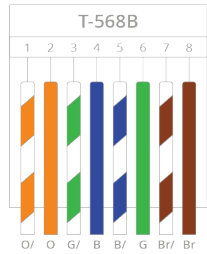

ALL IN ONE COMMS CONNECTION WITHOUT GIV-GATEWAY

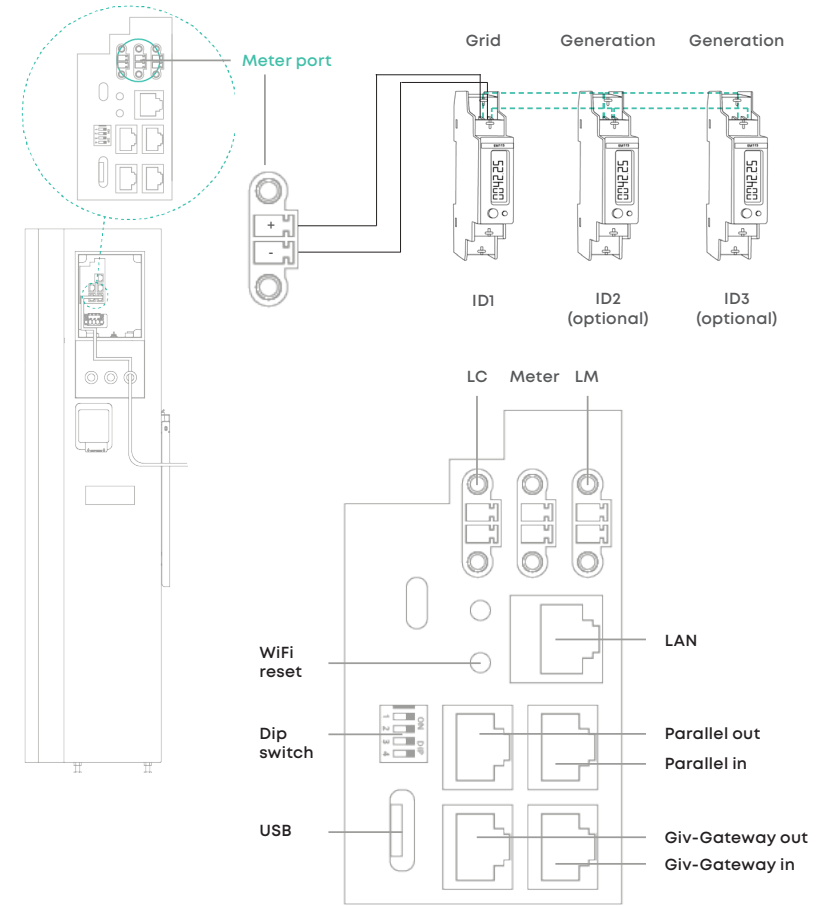

! We suggest that a twisted pair shielded cable is to be used for meter communication to lessen the risk of interference from external factors.

! The communication cable must be terminated with a RJ45 plug at either end to connect the All in One to the Giv-Gateway. Ensure the wiring configuration into the RJ45 is the same both ends, a cross-over cable will not work. A standard Ethernet Cat5/6 cable will suffice here, wired to T-568B standard if doing locally.

Note: If The length between GW and AIO is greater than 10m for better noise immunity please adopt a customised wiring pinout. There is a slight difference to the standard TIA568B pins; 5/8 and 6/7 are changed, as shown above.

GEM120CT OVERVIEW AND INSTRUCTIONS

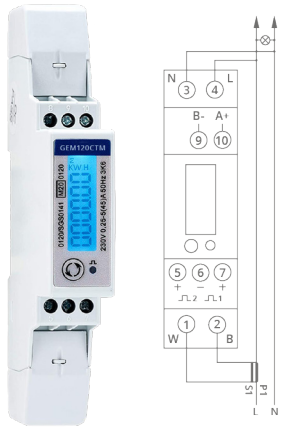

Technical Specifications

Model Number	GEM-CT-45/100
Dimensions (HxWxD)	119 x 17.5 x 62mm
Working Temperature	-25°C ~ 55°C
Protection Class	IP51
Display	LCD

Metering

Every system will need at least 1 GEM120 (ID1) meter installing to monitor the import and export of the building. Every GEM120 meter needs a power supply/voltage reference point. **This could be a dedicated supply from a 6A, for example.**

Every GEM120 meter will need a data connection back to the inverter's meter communication port. Please see the previous page for the connection point. **Data connection should be a twisted pair cable, for example, Belden multi-stranded cable.**

If installing multiple meters, both the data and power supply can be linked together in series.

GEM120 meters come with a split core CT that has a 2m cable. **This must not be cut down or extended.**

Press and hold the GEM120CT button to change the ID settings.

Please note: the GEM120CT meter is only to be installed for a standalone All in One, the Giv-Gateway already includes a pre-installed GEM120CT

Giv-Gateway Installation

SPECIFICATIONS



WHOLE HOME BACKUP A great companion to the AIO

By purchasing the additional Giv-Gateway, the All in One can provide whole house backup in the event of a grid failure.

The Giv-Gateway provides seamless switching between grid and battery ensuring that your property is always powered. The Giv-Gateway also facilitates a connection point for your solar PV system by allowing it to continue to generate energy even without a grid supply when in a grid outage scenario. Essential backup capacity varies dependent on model.

SPECIFICATION

Dimensions

410H x 190D x 370W (mm)

Weight

12.75Kg

Nominal AC Power

18.4 kW

Protection Class

IP65

Pollution Degree

Outside PD3;
inside PD2

Warranty

12 years

Max. AC Current

100A

Rated Grid Frequency

50/60±5Hz

Environmental Category

Outdoor

Model numbers

GIV-AIO-GW1

GIV-GATEWAY BOX CONTENTS

Item	Item Name	Qty
A	Giv-Gateway	1
B	Bracket	1
C	Mounting Screw	2
D	Wall Plug	2
E	Antenna	1
F	Key	1
G	M6 x 12 Bracket Screw	4

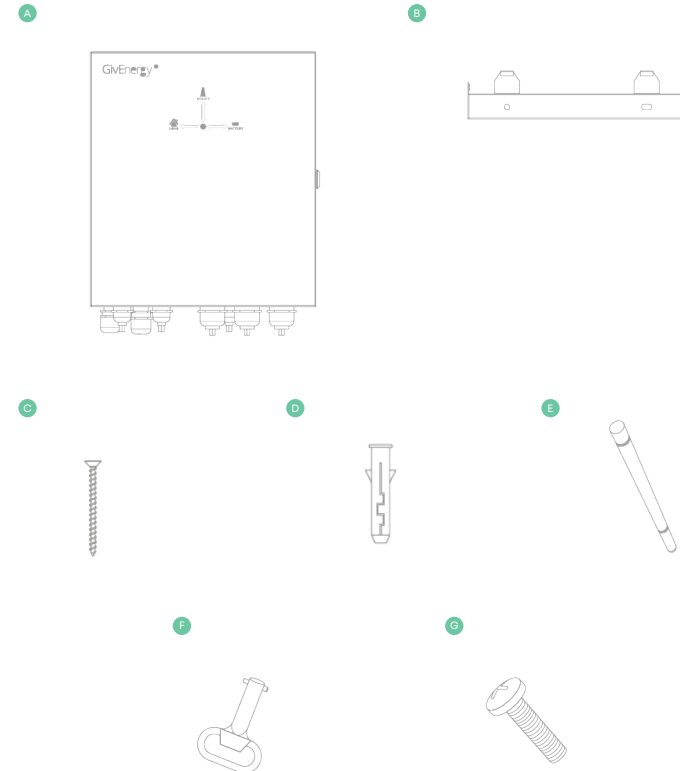

ISOLATING THE MAIN SUPPLY TO THE PROPERTY

Before installing the Giv-Gateway, make sure that the whole house is isolated from the main supply.

Once isolated, please test to ensure that no voltage is present to the property before disconnecting the main supply cable from the main distribution/switch board. The Giv-Gateway should be installed between the customer's supply meter and the switch board.

GIV-GATEWAY COMPONENTS

Item	Item Name
A	MCB, RCD
B	Grid / PV Meter and LoRa (spare)
C	CT, RS485, LAN, CAN, DRM

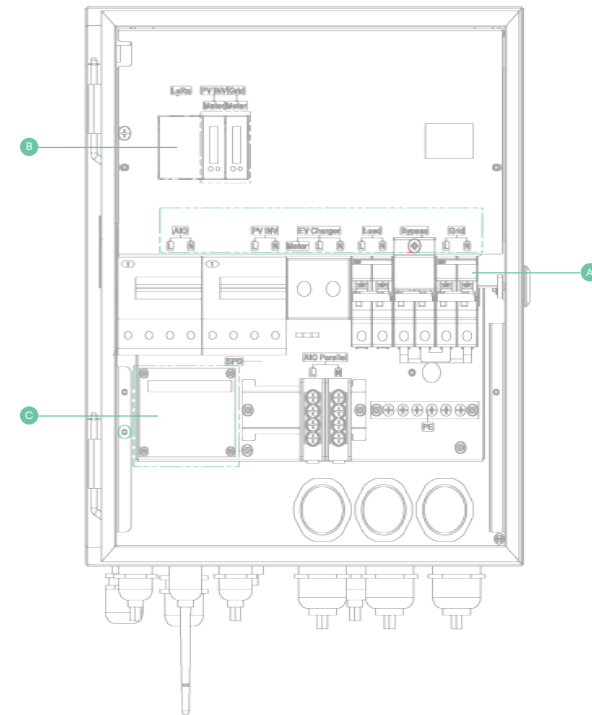

CLEARANCE AND MAINTENANCE

Space Clearance

There must be adequate clearance around the Giv-Gateway. The diagram below illustrates the space required around the system.

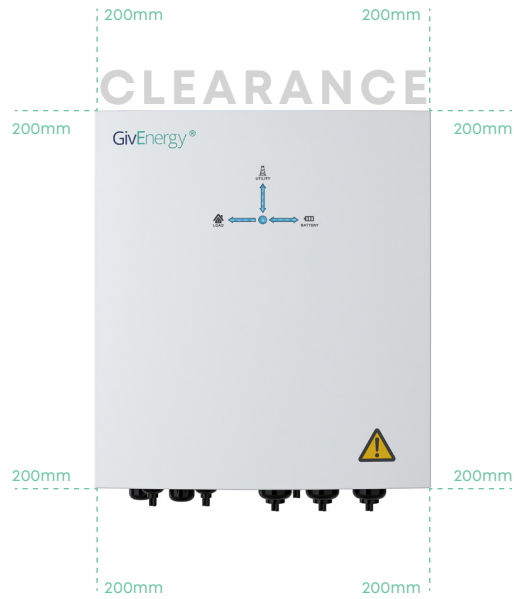

Maintenance

When maintaining and cleaning the Giv-Gateway, please refrain from using cleaning products on its surface.

To ensure your Giv-Gateway operates optimally at all times, annual maintenance checks need to be carried out. Check for visible damage or discolouration of the switches, and that the cables are intact. Please ensure that the top of the Giv-Gateway is not obstructed in any way.

GIV-GATEWAY STEP-BY-STEP INSTALLATION

Step 1: Place the wall mounting bracket horizontally onto the wall and mark the position of the bracket holes. Drill 2 holes at the marked positions, at least 75mm deep.

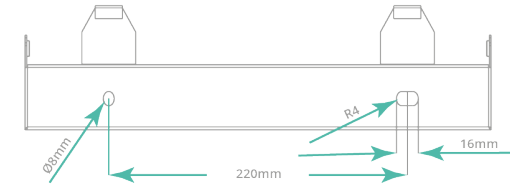

Step 2: Fix the mounting bracket to the wall using the fixings provided, or other suitable fixings.

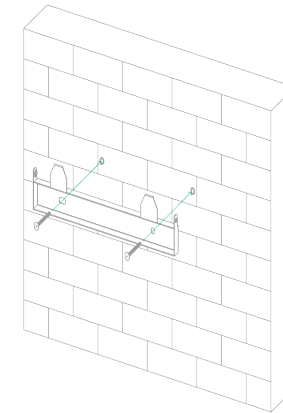

Step 3: Fix the Giv-Gateway to the mounting bracket and secure with the fixings provided. Ensure there is adequate clearance space.

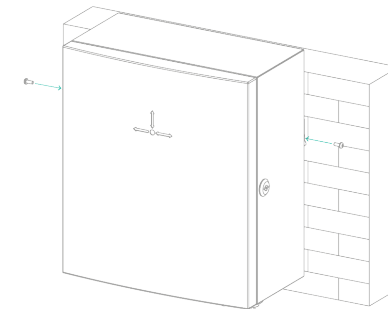

CONNECTIONS OVERVIEW

Item	Item Name
A	LoRa Connection Module (spare)
B	PV Meter (ID2)
C	Grid Meter (ID1)
D	Load (house supply)
E	AC Supply (in)
F	All in One Supply
G	PV Inverter Supply
H	EV Charger (spare)
I	All in One Parallel Connection (coming soon)*
J	Grid Bypass Switch

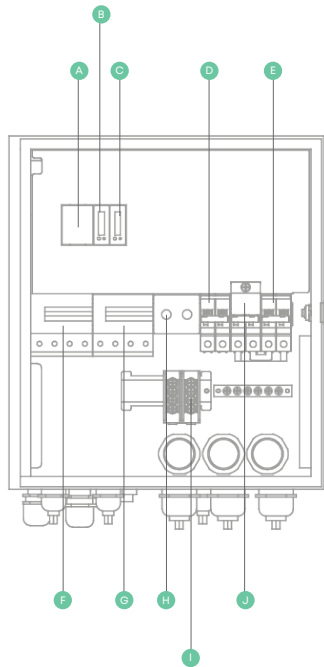

GIV-GATEWAY AC UTILITY GRID CONNECTION

➤ Breaker A - Single All in One Connection

The power wires for All in One connection should be at least 6mm². Strip the wire insulation for 8mm wiring connection.

➤ Breaker B - PV Inverter Connection

PV can be fed directly from this breaker. Please ensure that the overcurrent protection is adequate for the installation. If retro fitting the AIO + Gateway to a solar system, you can leave the existing PV feed in situ and just use a monitoring clamp to read the generation.

➤ Breaker C - EV Charger Connection

The maximum load current is 32A, so the load wires should be at least 6mm². Strip the wire insulation for 8mm wiring connection.

➤ Breaker D - Loads Connection

The maximum load current is 80A, so the load wires should be at least 16mm². Strip the wire insulation for 8mm to connect to this load breaker.

➤ Breaker E - Bypass MCB

The bypass switch redirects grid power directly to the house, bypassing the Giv-Gateway.

➤ Breaker F - Grid Connection

The maximum grid current is 100A. The tails should be 25mm² or larger. If the existing tails are less than 25mm, Breaker F should be derated accordingly, Strip 8mm of insulation to connect to the Grid breaker.

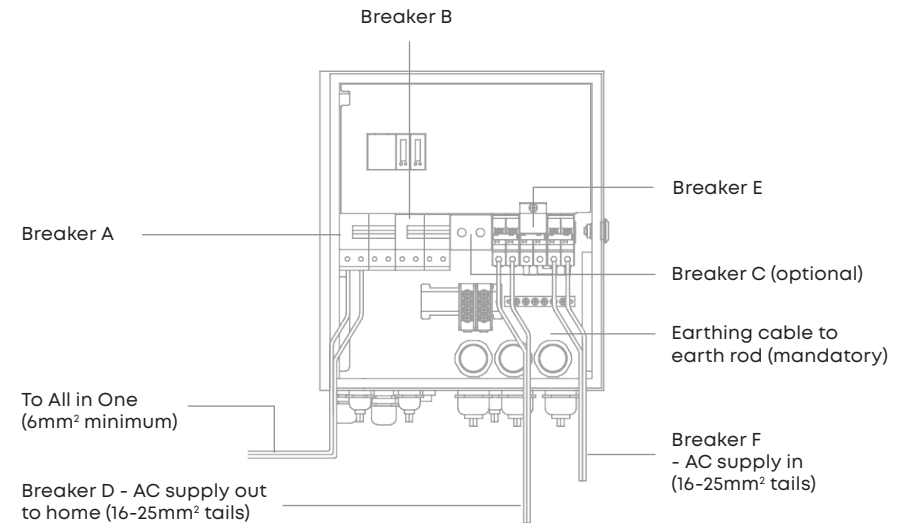

GIV-GATEWAY WIRING CONNECTIONS

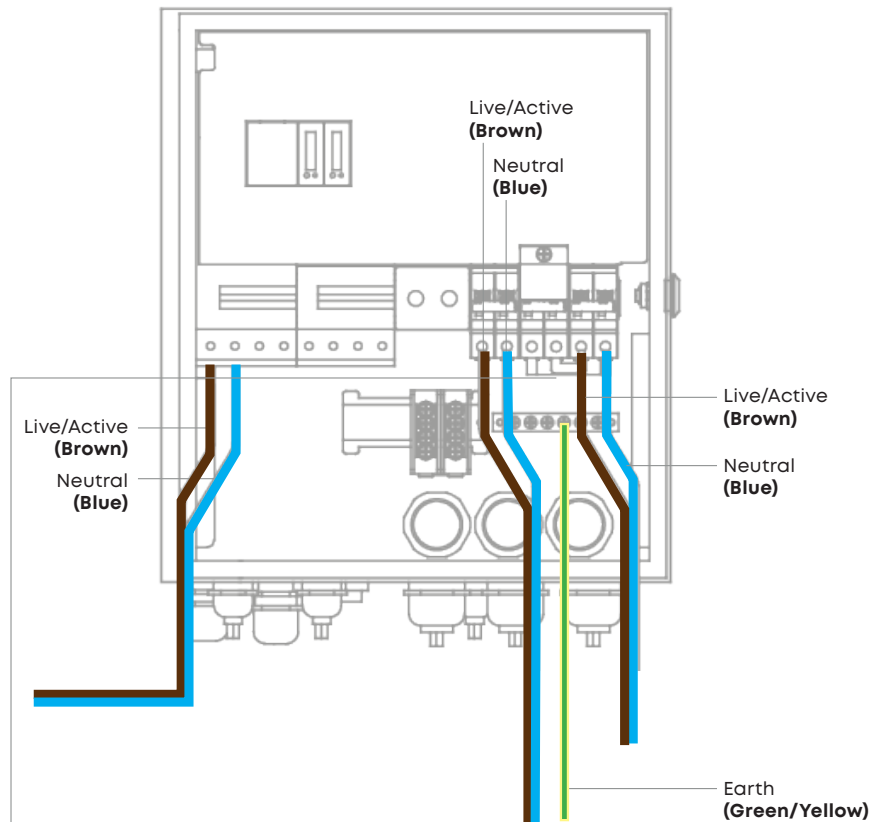

Earthing Cable to Earth Rod (Mandatory)

Please note: When using the earth terminal, this also earths the chassis and external metallic parts.

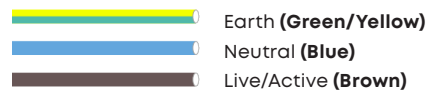

Type A RCD with 30mA tripping setting is already integrated in Giv-Gateway. For standalone version AIO, a Type A RCD with 30mA tripping current is recommended to be used.

ALL IN ONE NEUTRAL CONTINUITY

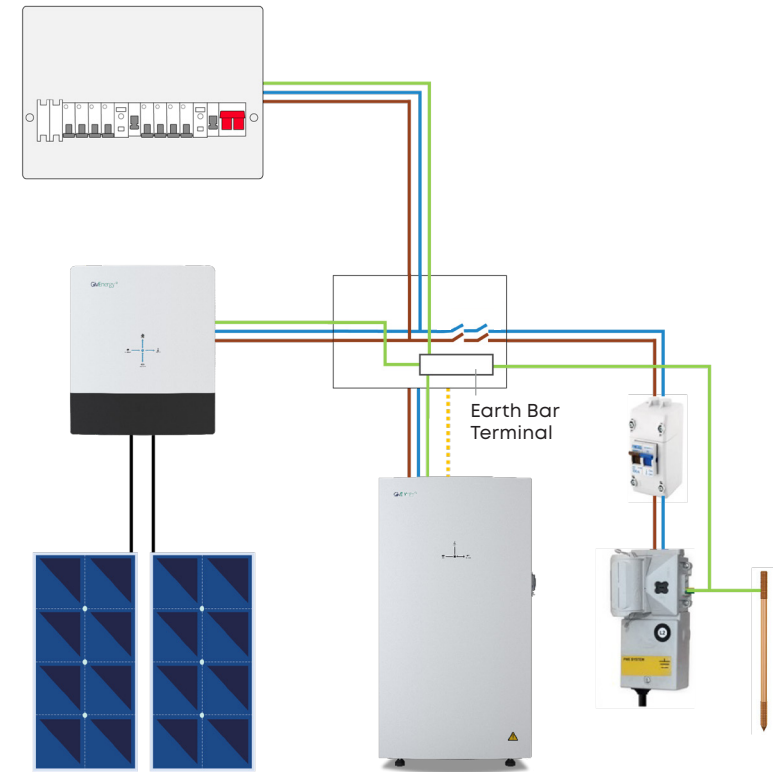

Grid Disconnect Relay

The Grid disconnect relay isolates both line conductors in the event of a power failure of the grid supply. The Earth is maintained at all times. Both the DNO earth and earth rod/disc are in parallel in accordance with BS7671, extract provided. In Island mode, the system adopts the TN-S earthing arrangement, as per the table below:

Connected Mode Earthing Arrangement	Island Mode Earthing Arrangement
TN-C-S	TN-S
TN-S	TN-S
TT	TN-S

GIV-GATEWAY COMMUNICATION CONNECTIONS

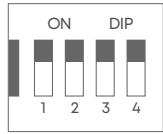

WiFi



LAN

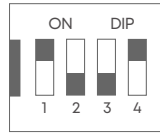

USB (Dongle) Mode

Gateway Communication/Network Ports

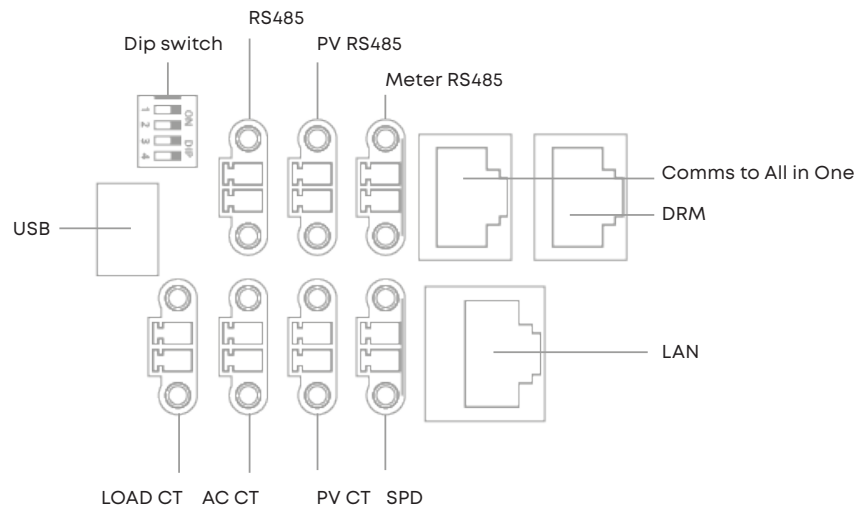

The meter tails between the meter position and the Giv-Gateway should not be longer than 3 metres. If the length is more than 3 metres, you should install an additional protective device at the nearest point to the supply inside the customer's premises, as specified in the current IEE Wiring Regulations.

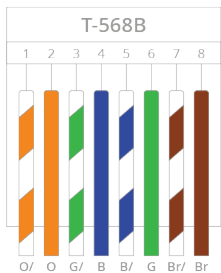

The communication cable must be terminated with a RJ45 plug at either end to connect the All in One to the Giv-Gateway.

Ensure the wiring configuration into the RJ45 is the same both ends, a cross-over cable will not work. A standard Ethernet Cat5/6 cable will suffice here, wired to T-568B standard if doing locally.

CONNECTING ALL IN ONE TO GIV-GATEWAY

AC Supply Wiring

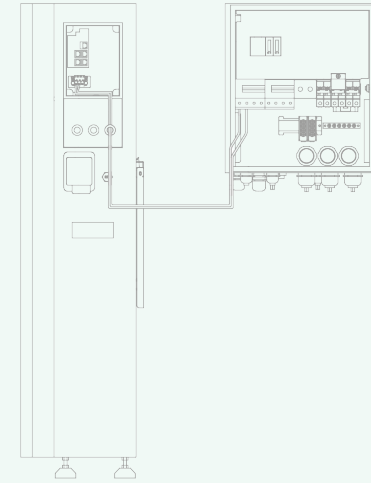

Communication Wiring

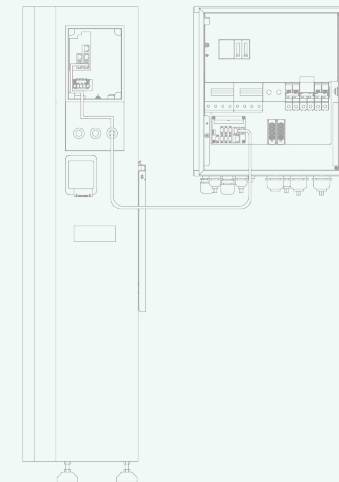

Remove bottom connections cover prior to wiring, and then replace once complete.

Once the equipment is assigned to the user during the commissioning process, the system will then connect to the **GivEnergy Monitoring Portal**. The inverter will report data to the GivEnergy Monitoring Portal, allowing information about the system to be displayed on the portal.

Please allow up to 24 hours for the data to be read in accurately.

Once the data is confirmed to be reading in correctly, the customer will be able to log in to their account via their device to manage and view their system.

For a more in-depth guide about our Monitoring Portal, please view our portal and app guide that is provided on our **Resource Hub at www.givenergy.com**.

Please note: the GivEnergy app is supported by an active development team constantly working on updates and improvements. As such, app information is subject to change.

Accessing Monitoring Data on the Portal

Step 1: Log into the GivEnergy Monitoring Portal at www.givenergy.cloud.

Step 2: After logging in, you'll be taken to the Monitoring Portal Dashboard. From here, you can view information about your systems import/export data, solar forecasts, tariff savings, and much more.

To view in-depth information about your consumption, you can expand the graph in the top left corner of the **Power Graph** window.



All in One & Giv-Gateway Configuration

SETTING UP MONITORING

Step 3: In the expanded view, you'll be able to view a detailed graph about your battery charge and discharge, battery percentage, as well as many other views.

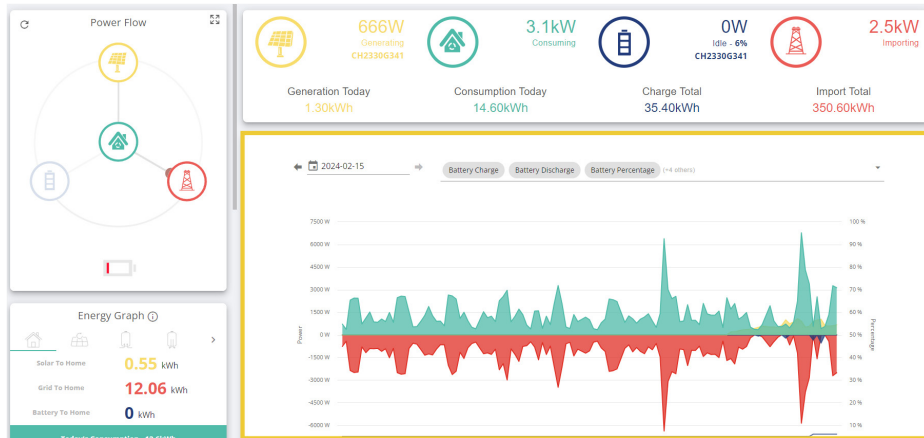

Step 4: To add/remove views, simply click the dropdown arrow and select from the dropdown list.

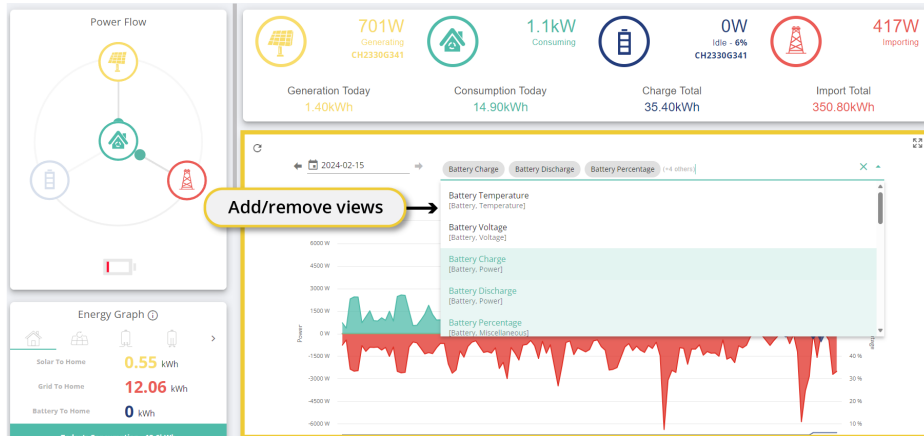

SETTING UP MONITORING

Accessing Data on the App

Step 1: Download the **GivEnergy App** from the Google Play / App Store on your device.

Step 2: Log in using your credentials.

Step 3: After logging in, you'll be shown the **App Dashboard**. This is a simplified version of the **GivEnergy Monitoring Portal**.

Step 4: The navigation menu displayed at the bottom of the screen allows you to cycle through your **Power and Energy Graph**.

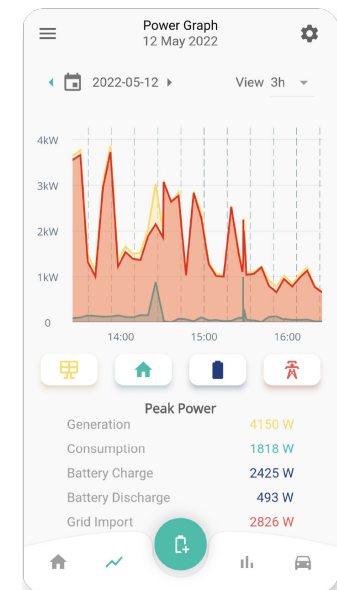

If data is not being displayed correctly on the GivEnergy Monitoring Portal or App, please contact the GivEnergy Service Desk on **01377 252 874** or email support@givenergy.co.uk.

Step 3: On the **Commissioning Page**, select **'Create Commission'** at the top of the window.

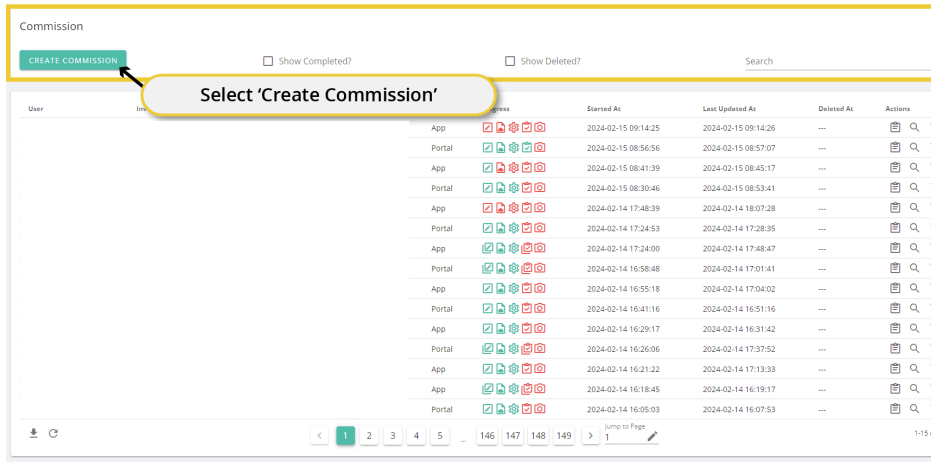

Step 4: You will now start the **Commissioning** process. Follow the instructions from Step 1 - 4. The region can be set in **Step 4** under **'Configure System'**.

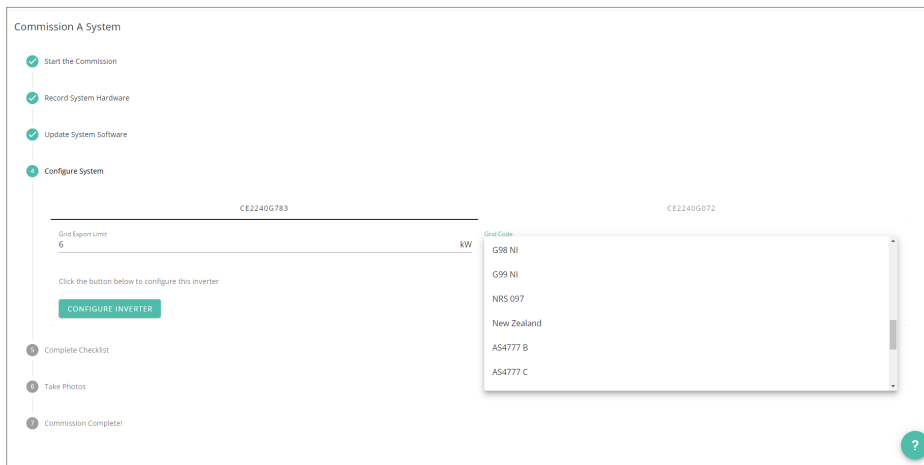

Step 5: Select the region from the dropdown list under **'Grid Code'**.

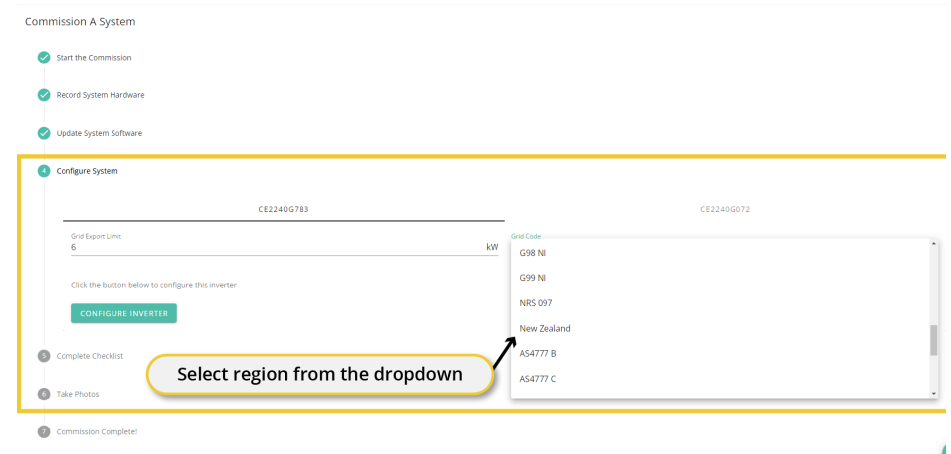

Step 6: Click **'Configure Inverter'** to confirm the region settings.

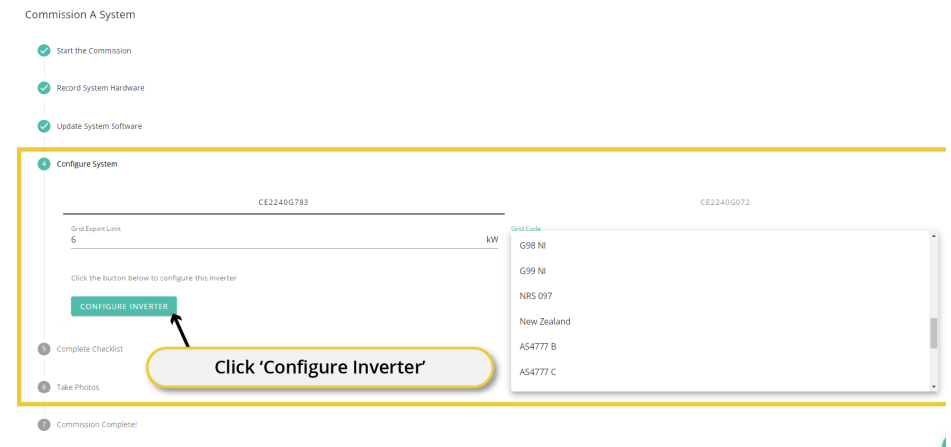

If the local grid operator requires other settings instead of the default please contact GivEnergy on **01377 252 874** or email support@givenergy.co.uk to change them remotely from GivEnergy's cloud server.

VIEW INVERTER FIRMWARE AND SETTINGS

To view your inverter firmware:

Step 1: Log into the GivEnergy Monitoring Portal at www.givenergy.cloud.

Step 2: On your portal dashboard, hover over the 'My Inverter' card and select the expand icon.



Step 3: Click 'Software' on the All in One card. You can cycle through your installed products using the arrows on either side of the window.



VIEW INVERTER FIRMWARE AND SETTINGS

Step 4: Your Inverter firmware version is displayed on this page. You can also update your firmware (if required) by pressing the 'Update Firmware' button. Click the arrow to cycle to your Giv-Gateway.

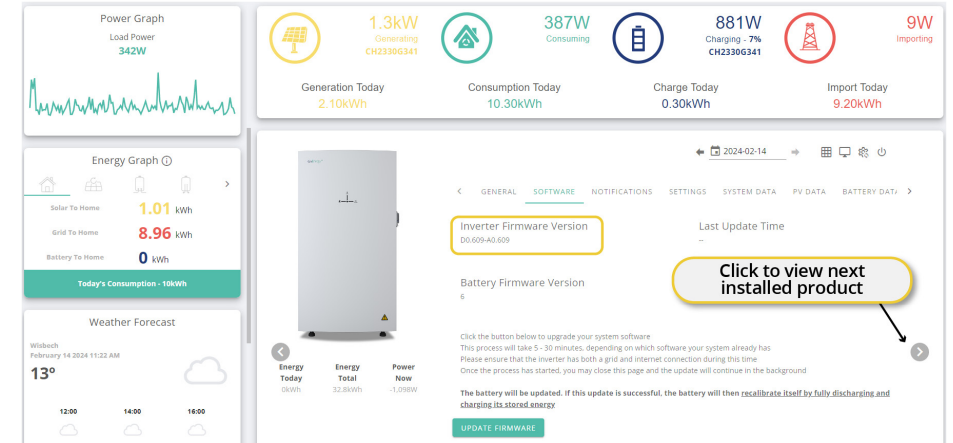

Step 5: Click 'Software' on the Giv-Gateway card.

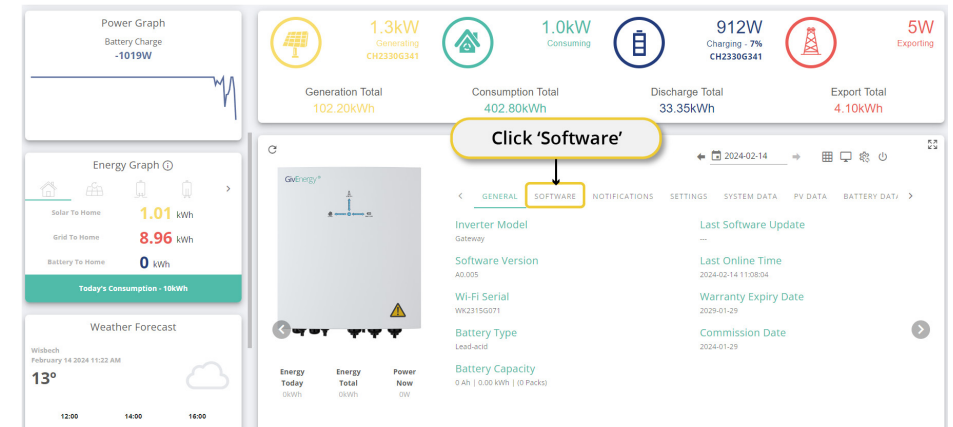

VIEW INVERTER FIRMWARE AND SETTINGS

Step 6: Your Giv-Gateway firmware version is displayed on this page.

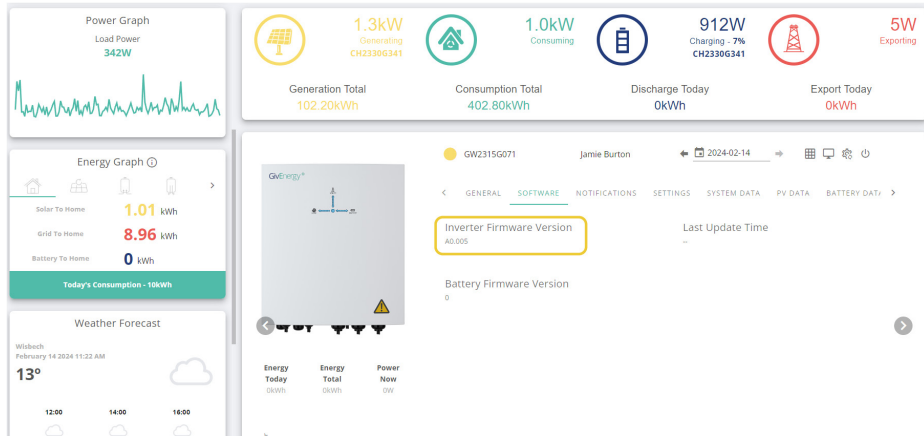

Step 7: Scroll down the page until you see the 'Control' section.

The screenshot shows the 'Control' section of the inverter settings page. It includes fields for 'System Time Year' (2024), 'System Time Month' (January), 'System Time Day' (29), 'System Time Hour' (16), 'System Time Minute' (2), and 'System Time Second' (47). There are also fields for 'Serial Number' with sub-sections for characters 1 & 2, 3 & 4, 5 & 6, 7 & 8, 9 & 10, and 'Software Version' with sub-sections for 'Inverter Model' and 'GSP Firmware Version'. A yellow callout box with an arrow points to the bottom of the page, containing the text: "Scroll down until you reach the 'Control' section".

GENERATION CONTROL & EXPORT CONTROL SETTINGS

To adjust generation and export control settings:

Step 1: Log into the GivEnergy Monitoring Portal at www.givenergy.cloud.

Step 2: On your portal dashboard, hover over the 'My Inverter' card and select the expand icon.



Step 3: In the 'My Inverter' screen, click the 'Remote Control' button found in the top right corner of the window.

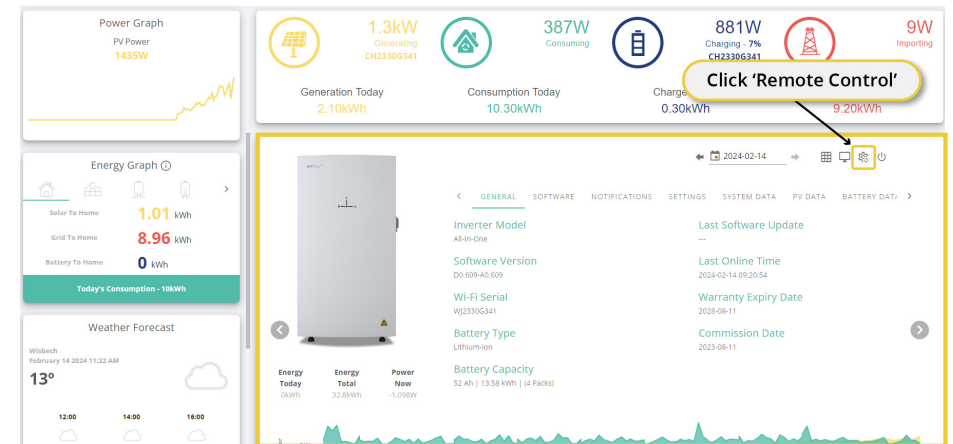

GENERATION CONTROL & EXPORT CONTROL SETTINGS

Step 4: Click 'Inverter' at the top of the Remote Control page.

Search Sorted Registers READ ALL UNREAD REGISTERS

General **Inverter** Battery Grid Meter Tariff Pricing Dongle Charge/Discharge Schedules

General
Restart Grid Code Meters/CT Battery Enable/Disable EPS Percentage Limits

Restart
Restart Inverter Restart Battery

Grid Code READ CATEGORY
Grid Code Unknown (3132) Grid Export Limit 6000 W
Enable G100

Meters/CT READ CATEGORY
Enable Meters 1x Meter CT Direction
Meter Type EMI 15

Step 5: Scroll down the page until you see the 'Control' section.

Inverter
Time & Date Serial Number Software Version PV Settings Control Grid Code General EPS Plant Settings General

Time & Date
System Time Year 2024 System Time Month January
System Time Day 29 System Time Hour 16
System Time Minute 2 System Time Second 47
Set Date and Time

Serial Number READ CATEGORY
Inverter Serial Number Characters 1 & 2 Inverter Serial Number Characters 3 & 4
Inverter Serial Number Characters 5 & 6 Inverter Serial Number Characters 7 & 8
Inverter Serial Number Characters 9 & 10

Software Version READ CATEGORY
Inverter Model DSP Firmware Version

Scroll down until you reach the 'Control' section

GENERATION CONTROL & EXPORT CONTROL SETTINGS

Step 6: To adjust Generation Control, adjust the slider in the 'Inverter Max Output Active Power Percent' field between 0 and 100%. This is a combined hard and soft limit.

Control READ CATEGORY

Enable Inverter DRM Inverter Max Output Active Power Percent 0 %
Inverter Max Output Reactive Power Percent On/Off State
Startup Time seconds Restart Delay After Fault seconds
Enable Bleep Force LAN
Reset Energy Totals Enable Firmware Update Flag

Grid Code READ CATEGORY
Inverter Nominal Power W EN5049 Zero-Current Static Voltage Limit 0 V
EN5049 Zero-Current Static Upper Voltage Limit 0 V

General READ CATEGORY
Disable Safety Checks Connection Loading Slope 10
Export Power Priority Underfrequency Add Load Delay 0 s

Slide to adjust

Step 7: To adjust the Export Control, scroll back to the top of the page and under 'Grid Code' in the 'General' section, toggle to enable G100 in the 'Enable G100' field.

Search Hide Potentially Unsupported Registers READ ALL UNREAD REGISTERS

General Inverter Battery Grid Meter Tariff Pricing Dongle Charge/Discharge Schedules

General
Restart Grid Code Meters/CT Battery Enable/Disable EPS Percentage Limits

Restart
Restart Inverter Restart Battery

Grid Code READ CATEGORY
Grid Code Unknown (3132) Grid Export Limit 6000 W
Enable G100

Meters/CT READ CATEGORY
Enable Meters 1x Meter CT Direction
Meter Type EMI 15

Toggle to enable

Step 8: Adjust the **Export Limit** by sliding the value in the 'Grid Export Limit' field. This is a combined hard and soft limit.

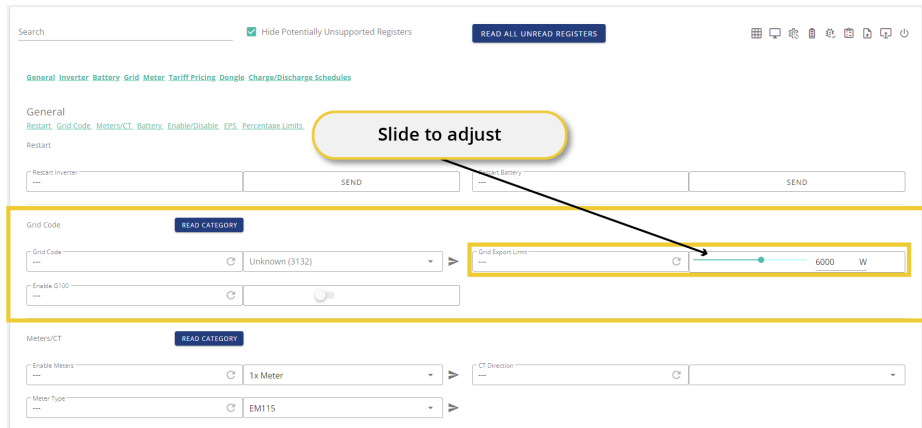

WE / WF / WO / WG / WH / WJ / WK Serial Number

Step 1: Accessing your WiFi settings

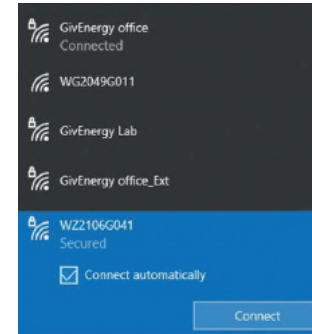

Accessing your **WiFi settings**.

Select the WiFi network that matches the dongle **serial number**.

Click Connect when it is visible (ensure **Connect automatically** is ticked)

Step 2: Logging in to your local inverter WiFi settings

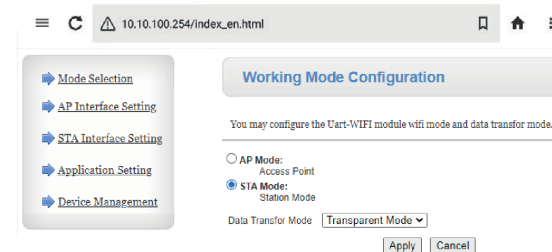

Open your **web browser** (preferably Google Chrome). Type **10.10.100.254** into the address bar.

When prompted enter:
Username: admin
Password: admin*

Step 3: Select Mode

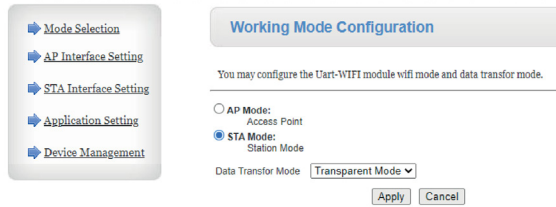

Select **Mode Selection**.
Select **STA mode**.
Click **Apply**.

Step 4: Connecting to your WiFi

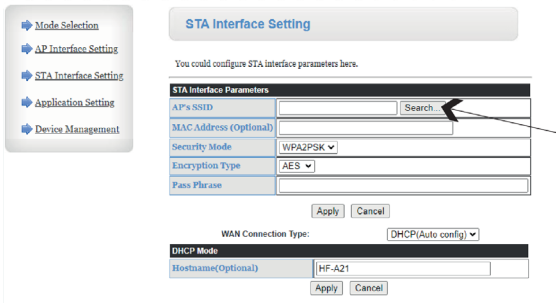

Select **STA Interface Setting**.
Click the **Search** button.

Step 5: Selecting your WiFi network

Site Survey							
	SSID	BSSID	RSSI	Channel	Encryption	Authentication	Network Type
<input checked="" type="radio"/>	GivEnergy Lab	74.da.88.95.c7.de	37%	6	AES	WPA2PSK	Infrastructure
<input type="radio"/>	DISPLAY_TABLETS	06.ec.da.3b.77.5d	26%	6	AES	WPA2PSK	Infrastructure
<input type="radio"/>	WF2125G793	34.ea.e7.7f.e6.5c	89%	11	NONE	OPEN	Infrastructure
<input type="radio"/>	HideSSID	76.ac.b9.97.33.e6	83%	11	AES	WPA2PSK	Infrastructure
<input type="radio"/>	WE1812G001	f0.fe.8b.73.4b.98	20%	11	AES	WPA2PSK	Infrastructure
<input type="radio"/>	WZ2108G038	98.d8.63.9b.29.b9	78%	11	NONE	OPEN	Infrastructure
<input type="radio"/>	WF2026G304	98.d8.63.97.37.fc	100%	11	NONE	OPEN	Infrastructure

Apply Refresh

Select your **WiFi network** from the list.
Click **Apply**.
Click **Refresh** if your network doesn't appear (see troubleshooting for more support).

RSSI (signal strength) should be at least 60% for a reliable signal.
A WiFi booster/extender may be required if signal strength is <60% (see diagram).

Step 6: Inputting your WiFi password

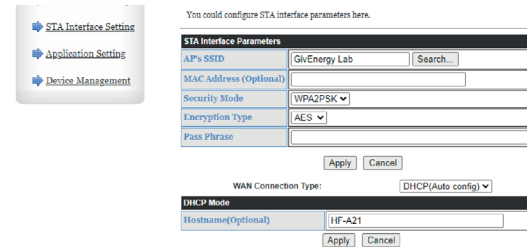

Note: If the desired network does not appear, you can manually enter it here. Enter the customer's WiFi password.
Click **Apply**.

Step 7: Setting your security modes

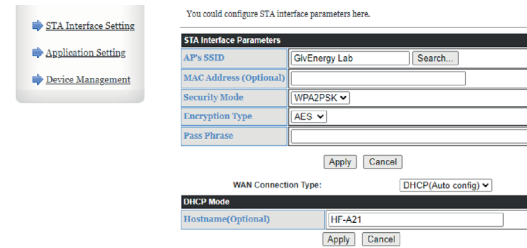

Select **AP Interface Setting**.
Select **WPA2-PSK** from the drop down menu in **Security Mode**.
Click **Apply**.

To hide the WiFi network name of the dongle when it is broadcasting you can tick the hide SSD box.

If you are having interference on a WiFi channel, or if it is causing issues with your home WiFi you can try changing the WiFi channel here.

If you wish to change the IP address of the dongle you can modify this here.

Step 8: Selecting your dongle password

The screenshot shows the 'AP Interface Setting' menu with a sidebar on the left containing: Mode Selection, AP Interface Setting, STA Interface Setting, Application Setting, and Device Management. The main content area is titled 'AP Interface Setting' and contains three sections:

- Wireless Network:** Network Mode (11b/g/n mixed mode), Network Name (SSID) (WF2141G615), BSSID (28 9C 6E 3F 55 B4), Frequency (Channel) (2437MHz(channel 6)), and Wireless Distribution System(WDS) (WDS Configuration). Buttons: Apply, Cancel.
- WPA:** Security Mode (WPA2-PSK), WPA Algorithms (TKIP, AES, TKIP/AES), and Pass Phrase (SA1234G6567). Buttons: Apply, Cancel.
- LAN Setup:** IP Address (Default DHCP Gateway) (10.10.100.254), Subnet Mask (255.255.255.0), and DHCP Type (Server). Buttons: Apply, Cancel.

Choose a **password** (inverter serial no. is recommended).
Click **Apply**.

Step 9: Restart dongle

The screenshot shows the 'Device Management' menu with a sidebar on the left containing: Mode Selection, AP Interface Setting, STA Interface Setting, Application Setting, and Device Management. The main content area is titled 'Device Management' and contains four sections:

- Administrator Settings:** Account (admin), Password (admin). Buttons: Apply, Cancel.
- Restart Module:** Restart Module (Restart).
- Load Factory Defaults:** Load Default Button (Load Default).
- Update Firmware:** Location (Choose file) No file chosen. Button: Apply.

Select **Device Management**.
Select **Restart**.

The screen will display Rebooting, this will stay on your screen indefinitely but the process only takes at maximum 10 minutes. If after 10 minutes your system is still not connected refresh your page and then please try the steps again, or refer to our **Troubleshooting** steps in our full guide on our website.

Commissioning Overview

All systems must be commissioned to ensure correct battery and meter communications, as well as connection to the online portal.

Note: Without commissioning, the system may not operate correctly.

Check that all the wires are securely connected before the battery breaker and the AC isolator is switched on. You **MUST** set the parameters of the battery according to your battery system.

When commissioning the system, please use the **GivEnergy app** available from the **Google Play/ App Store** and refer to our **GivEnergy Portal and App guide** found on our Resource Hub on the GivEnergy website.

When you start a commission, you will be prompted to input the grid code from a drop down list. Please confirm with your local grid operator on which Region to select.

Accessing the Commissioning Portal/GivEnergy App

Either sign into the online portal at <https://portal.givenergy.cloud>, or the GivEnergy app with your GivEnergy Engineer login. If you are a first time user, and you do not have an account or Engineer login, please consult your supplier to get this set up.

➤ To download a fully illustrated guide, please visit our Resource Hub on the GivEnergy website.

Setting Up the Internet Connection

Sign into the **GivEnergy app** and follow the in-app instructions.

End User Account Creation

To set up GivEnergy account the end user will provide their email address to the installer/ installation company. Upon successful commission of the equipment the end user will be emailed with a prompt to set up their account and gain access to the portal. Upon signing in to the portal for the first time they will go through a walk-through explaining how to navigate the portal and mobile app.

Decommissioning the System

To decommission the system please contact GivEnergy either by phone on **01377 252 874** or email at **support@givenergy.co.uk**.

Please confirm with your local grid operator on which Region to select.

All in One & Giv-Gateway Fundamentals

UNDERSTANDING YOUR ALL IN ONE

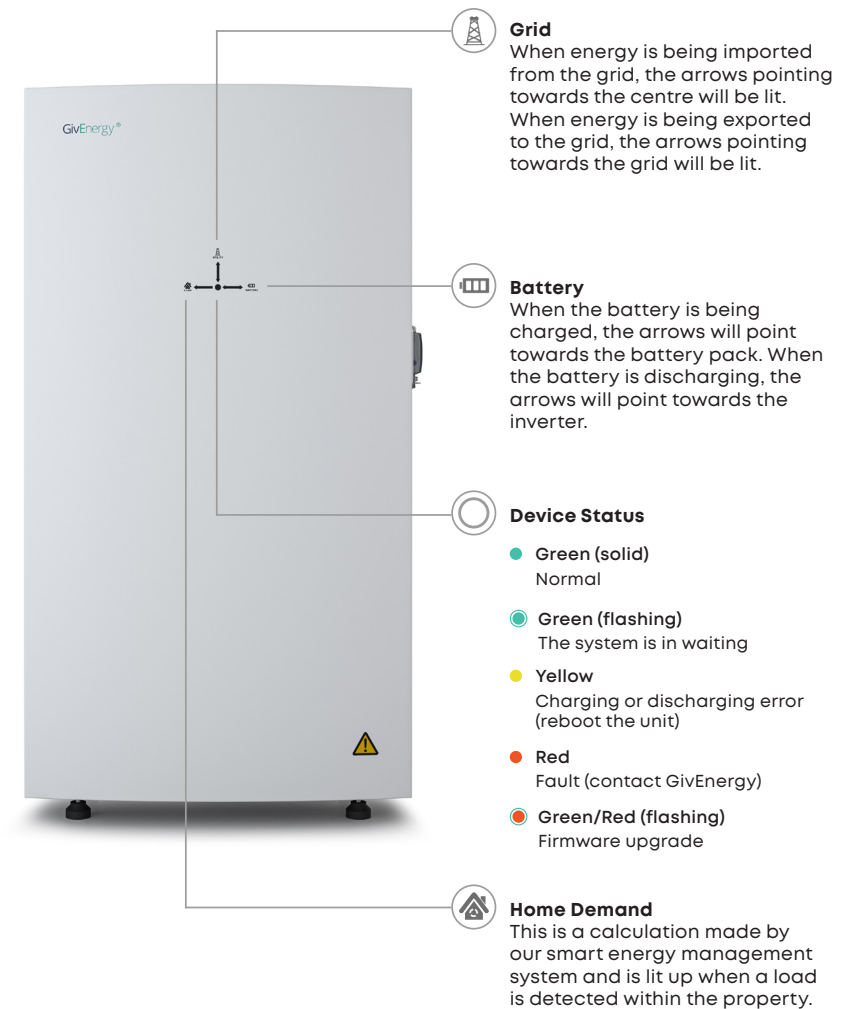

UNDERSTANDING YOUR GIV-GATEWAY

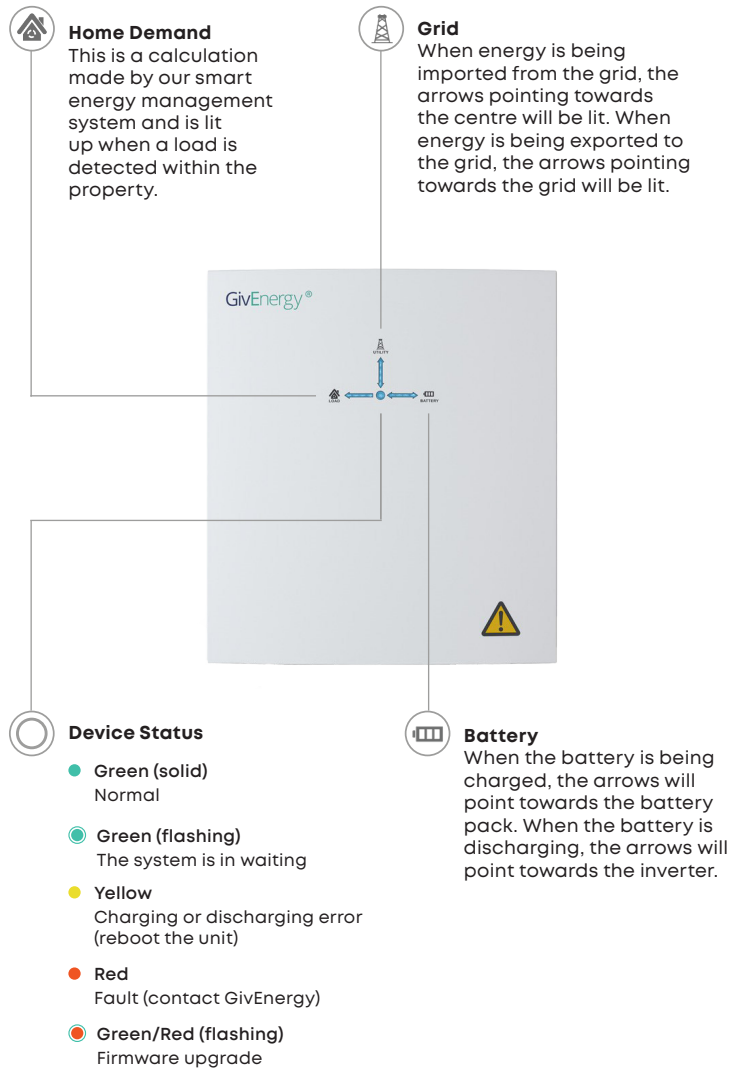

ALL IN ONE INSTALLATION WITH GIV-GATEWAY

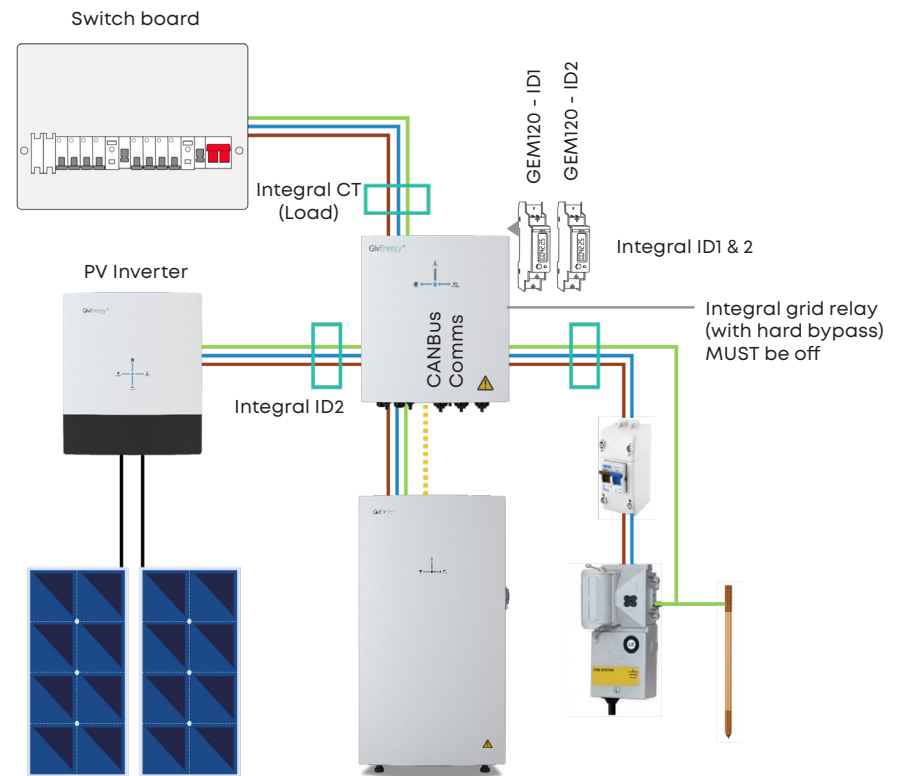

! An earthing rod MUST be installed.

ALL IN ONE INSTALLATION WITHOUT GIV-GATEWAY

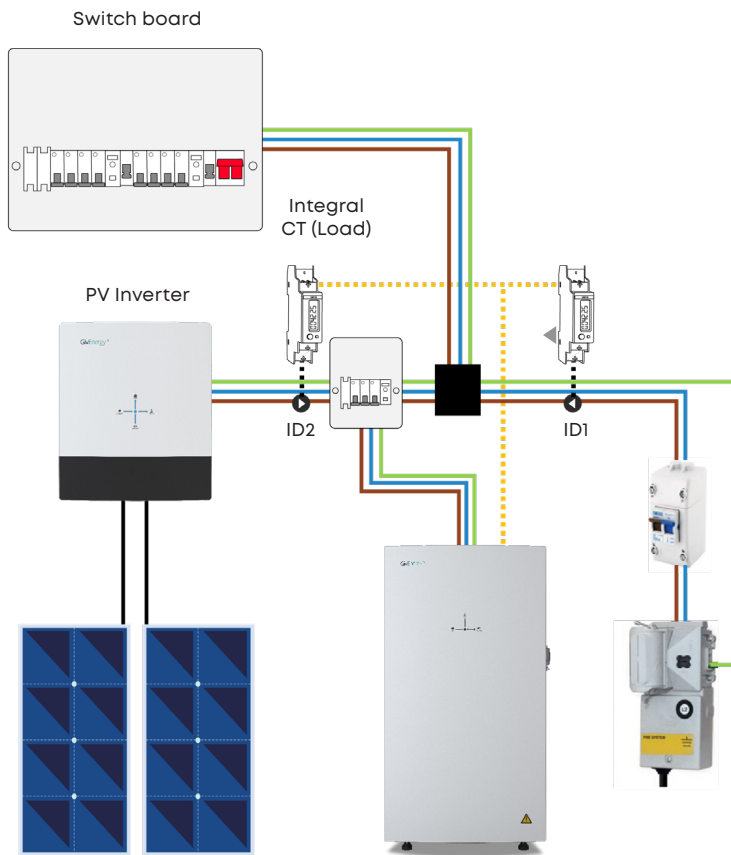

WORK MODES



Off Peak Charging

This is prioritised to charge the battery during off peak times when energy is cheaper, greener, and cleaner. The battery will start to discharge outside of the off peak time when energy is more expensive.



Solar Charging

This is prioritised to charge the battery utilising excess solar generation, when energy is cheaper, greener, and cleaner. The battery will start to discharge outside of the peak generating hours when energy is more expensive.



Back Up / Island Mode

The system has the ability to be used in the event of a power cut. To utilise this the All in One must be connected to a Giv-Gateway. In the event of a power cut the Giv-Gateway will seamlessly switch over to battery to power the whole home.



Off Grid Operation

Remotely disconnect your home from the grid at the push of a button using the **GivEnergy App** or **Online Monitoring Portal**.

MANUFACTURER WARRANTIES

The All in One and Giv-Gateway are covered by **12-year warranties**.



All in One / All in One 3.6 / 13.5
12-year warranty



Giv-Gateway
12-year warranty

Warranty documents can be found on our resource hub on the GivEnergy website.

Legal Disclaimer: This document is the property of GivEnergy, reproduction is prohibited.

GivEnergy

Phone

UK +44 01377 252 874
NL +31 85 208 6376

Email

UK support@givenergy.co.uk
NL support@givenergy.com
SA support.sa@givenergy.com
AU martin.cobb@givenergy.com

Website

www.givenergy.com