



ALL IN ONE 2 | AC COUPLED

All in One 2, MPPT Unit, Gateway 2, Expansion Battery User Manual

GIV-AIO-AC-6.0/8.0/10.0/11.0/12.0,
GIV-BAT-13.5-AIO2, GIV-MPP-20.0-G1,
GIV-AIO-GW1-2, GIV-BAT-13.5-AIO2-E

LEGAL INFORMATION

Warning Notice System	4
Qualified Personnel	4
Proper Use of GivEnergy Products	5
Warranty	5
Trademarks	5
Disclaimer of Liability	5
Retention of This Manual	5

SAFETY

Safety Symbols Description	6
General Safety	7
Electrical Safety	7
Grounding Requirements	7
PV String Side Operation	8
Inverter Requirements	9
AC Side Operation	9

PRODUCT DESCRIPTION

Introduction	10
System Components	11
System Diagrams	12
All in One 2	14
Interface Description	14
Specification	15
MPPT Unit	17
Interface Description	17
Specification	17
Expansion Battery	18
Interface Description	18
Specification	18
Gateway 2	19
Interface Description	19
Specification	19
Key Features	22
Inverter Operating Modes	23
Main Work Modes	24
Daytime Mode	24
Night-time Mode	24
Island Mode	25
Demand Response Mode	25

INSTALLATION

Unpacking Inspection	26
Packaging List	26
All in One 2	26
Gateway 2	27
MPPT Unit	27
Safety Instructions	28
Mounting Area	29
Installation Procedure	30
All in One 2 and MPPT Unit (Desk)	30
Gateway 2	34
Electrical Connection	35
Desk AC Connection	35
Gateway 2 AC Connection	36
Communication Connection	40
System Communication Connection	40
Gateway 2 Communication Port	41
All in One 2 Communication Port	42
Wireless Communication	43
DRM (Demand Response Management)	43

SYSTEM COMMISSIONING

Pre-Commissioning Checks	44
System Startup and Shutdown	45
Start-Up the Inverter	45
Disconnect the Inverter (Shutdown)	45
Equipment Parameter Setting and Monitoring	45

MAINTENANCE

System Power-Off for Maintenance	46
Regular Maintenance	46

TROUBLESHOOTING

Troubleshooting	47
-----------------	----

SYSTEM REMOVAL AND DISPOSAL

Remove Machine	51
Scrap Machine (Disposal)	51

Warning Notice System

This manual contains important safety notices to ensure your personal safety and prevent damage to property. These notices are identified by specific symbols and are categorized according to the severity of the potential hazard. Please read and follow these warnings carefully.



DANGER

Indicates an immediate hazard that will result in severe injury or death if not avoided. It's the highest level of risk.



WARNING

Indicates a potential hazard that could result in serious injury or death if not avoided. It's slightly less severe than "Danger."



CAUTION

Indicates a potential hazard that could result in minor injuries or property damage if not avoided.



NOTICE

Used to provide additional, helpful information. It doesn't indicate hazards.

Qualified Personnel

The GivEnergy All in One described in this manual must only be installed and maintained by qualified personnel. Qualified personnel are individuals who have received training in electrical systems and photovoltaic (PV) installations (not required for AC Coupled only installations) are familiar with local electrical codes and regulations, and are able to identify risks and avoid potential hazards associated with handling high-voltage equipment.

To ensure proper installation and compliance with manufacturer guidelines, GivEnergy requires the equipment to be installed by a GivEnergy-approved installer. Approved installers have undergone specialized training on GivEnergy products, ensuring safe and efficient installation, commissioning, and operation.

Improper installation or operation of this product by unqualified personnel may result in personal injury, property damage, or voiding of the warranty.



WARNING

- ✔ Use only components and accessories recommended or approved by GivEnergy.
- ✔ Adhere strictly to the procedures outlined in this manual for transport, storage, installation, commissioning, operation, and maintenance.
- ✔ Ensure compliance with all local safety codes and regulations.
- ✔ Operate the product only within the specified environmental and electrical conditions detailed in the manual.

Proper Use of GivEnergy Products

The GivEnergy All in One is designed for energy storage and management in photovoltaic systems. To ensure safe and reliable operation, always follow the provided instructions. Failure to do so may result in unsafe operation, product damage, or warranty invalidation.

Warranty

The GivEnergy All in One is covered by a standard 15-year warranty from the commissioning date, which must be completed by an approved installer via the GivEnergy portal or Installer App.



For warranty claims or inquiries, please contact GivEnergy Support or your authorized distributor.

Trademarks

All names and logos identified in this document are the property of GivEnergy. Unauthorized use of GivEnergy trademarks is prohibited. All other trademarks mentioned remain the property of their respective owners.

Disclaimer of Liability

This document is the property of GivEnergy. Any reproduction, modification, or distribution of this manual without prior written consent from GivEnergy is strictly prohibited.

The content of this manual has been carefully reviewed for accuracy and is consistent with the product described. However, due to ongoing product improvements and updates, GivEnergy cannot guarantee complete consistency. Any necessary corrections or updates will be included in subsequent editions of this manual.

Retention of This Manual

This manual contains essential information for the assembly, installation, commissioning, and maintenance of the GivEnergy All in One. It must be retained for future reference and made accessible to all qualified personnel involved in the operation and maintenance of this product.

Safety Symbols Description



DANGEROUS VOLTAGE

The product works with high voltage. Only qualified tradespeople must do work on the product. They must follow the product's documentation.



HOT SURFACE

The product can get hot when it works. Do not touch the product when it is working.



OBSERVE OPERATING INSTRUCTIONS

Read the product's documentation before you work on it. Follow all safety precautions and instructions in the documentation.



GROUND PROTECTION

Shows the connection point for grounding protection.



DIRECT CURRENT (DC)



ALTERNATING CURRENT (AC)



ELECTRIC SHOCK RISK (5 MINUTES)

Signals danger from electric shock. It shows the time (5 minutes) to wait after the inverter is off and disconnected. This ensures safety in any installation operation.



CE MARK

The inverter meets the requirements of applicable CE guidelines.



DO NOT DISPOSE WITH HOUSEHOLD WASTE

The Hybrid inverter must not be disposed of with household waste.

General Safety

The GivEnergy All in One system is a high-voltage device. Incorrect installation, handling, or maintenance can cause serious injury, death, or equipment damage.

To ensure safe operation, always follow the guidance below:

- Please read this document carefully to understand the products and precautions before installing the device. The terms “caution”, “warning”, and “danger” in the manual do not represent all safety precautions to be observed, but only supplement all safety precautions.
- All equipment operations must be carried out by professional and qualified electrical technicians. They must be familiar with the relevant standards and safety specifications of the project location.
- When the inverter is operated, it is necessary to use insulating tools and wear personal protective equipment to ensure personal safety.
- When contacting electronic devices, wear electrostatic gloves, electrostatic bracelets, and anti-static clothing to protect the inverter from electrostatic damage
- It is strictly forbidden to install, use, and operate outdoor equipment and cables in bad weather such as lightning, rain, snow, and high winds. This includes but is not limited to handling equipment, operating equipment and cables, plugging and unplugging signal interfaces connected to outdoors, working at height, and outdoor installation.
- Please follow the requirements of this manual. Use the correct tools and master the correct use of the tools. Please follow the warning signs, warnings, and protective measures on the equipment.
- It is forbidden to carry out installation, wiring, maintenance, and replacement operations with electricity on. Safe isolation procedures must be completed, to confirm that there is no risk of electric shock, while conducting maintenance on the equipment
- When transporting, turnover, installation, wiring, and maintenance, etc., it must meet the laws and regulations and relevant standards of the country and region where it is located.
- The materials provided by the user and the tools required during operation must meet the requirements of the laws, regulations, and relevant standards of the country and region where they are located.
- Do not disassemble the system equipment at will.

For additional safety and warranty information, visit the official GivEnergy website.

Electrical Safety

Grounding Requirements

Equipment must be grounded. When installing, you must first install a protective earth wire. When removing equipment, the protective ground wire must be removed last. The grounding of the energy storage inverter meets the local requirements for the grounding of photovoltaic modules and energy storage inverters. This is to ensure continuous conduction with the ground in order to optimally protect the system and personnel.

**CAUTION**

- ✔ It is strictly forbidden to operate the equipment on equipment that is not grounded.
- ✔ Live equipment may cause injury to the operator.
- ✔ It is necessary to check whether the grounding is good in advance when operating the equipment.

PV String Side Operation

Please use the MC4 connectors supplied with the box to connect the inverter DC cable. Using other models of MC4 connector can cause overheating of the connections and invalidate the warranty.

It is recommended that the panel string be connected to the equipment to add a DC isolator. Before the electrical connection of the equipment, if it may encounter a live part, the DC isolator should be in the off position. Only when the MC4 connections are all correct, shall the DC isolator be turned on.

Ensure correct polarity of the DC cable to ensure that the positive and negative poles are correct and there is no reverse connection. Ensure the voltage is within the permissible range. Reverse polarity will cause overcurrent and damage to the equipment.

The unit is a transformerless inverter. It has no galvanic isolation. Do not ground the DC circuit of the PV modules to the inverter. Ground only the mounting frame. If you bond PV modules to the inverter, you will receive an error message "PV ISO is low".

PV modules with large land capacity, such as thin-film PV modules with cells on metal substrates, can only be used if their coupling capacity does not exceed 470nF.

During feed-in operation, leakage current flows from the battery to the earth. The magnitude of which depends on how the PV modules are installed (e.g., foil on a metal roof) and the weather (rain, snow). This "normal" leakage current should not exceed 30mA, as the inverter will automatically disconnect from the grid as a protective measure.

To disassemble, unplug, and maintain the inverter DC string terminal wire, it must be confirmed that the equipment switch, and the corresponding breaking device of the previous stage are disconnected. Confirm that the equipment and machine are stopped and there is no work.

**DANGER**

- ✔ Sparks and arcing may result if the DC connections are inserted or removed while live.
- ✔ Touching exposed live parts can result in electric shock
- ✔ Sparks and arcs can cause fires.

Inverter Requirements

Ensure that the voltage and frequency of the grid supply are correct for the equipment being installed.

It is recommended that the AC power grid add an isolation device to the equipment. The inverter AC side must have overcurrent protection suitable for the inverter being installed.

The specifications of the protection device should be greater than 1.25 times the maximum current of the inverter AC output.



DANGER - LETHAL VOLTAGE

- ✔ Lethal voltage is present inside the device and on the supply cabling.
- ✔ Therefore, only authorized electricians can install and open this unit.
- ✔ Even if the device is disconnected, high contact voltages may still exist within the device.
- ✔ There is a high voltage inside the machine. Unauthorized non-professionals opening and touching the internal devices can cause electric shock and cause personal injury.



WARNING - HOT SURFACE

- ✔ Risk of burns due to overheating of housing parts! During operation do not obstruct the heatsink, this will prevent proper operation of the cooling functions.
- ✔ The product can become hot during operation. Do not touch the product during operation.

AC Side Operation

Please connect the wire L/N/PE on the AC side of the single-phase inverter equipment according to the instructions in this manual. Incorrect connection of the wire sequence may cause damage to the equipment and cause leakage and electric shock.

The AC wire must be disconnected by the corresponding isolation device of the previous stage before being connected to the equipment. Do not short circuit the AC line.

Disassembling, unplugging, and maintaining the AC connection wires of the inverter must confirm that the power is disconnected from the grid. Confirm that the equipment and inverter are powered off and not working.



DANGER - LETHAL VOLTAGE

- ✔ Do not disconnect the AC side of the inverter while it is connected (isolate it first using the AC isolation point).
- ✔ Do not touch exposed live parts, electric shocks can kill.
- ✔ Sparks and arcs can cause fires.

Introduction

The GivEnergy All in One 2 (AIO2) is a fully integrated energy solution combining a bi-directional inverter and a 13.5kWh battery. The system is designed for energy storage, solar integration, and flexible load management.

The system supports:

- Multi-channel PV input via the MPPT Unit (6 PV channels).
- Smart load and grid management through the Gateway 2.
- Optional capacity expansion using external batteries.

The GivEnergy All in One system supports advanced energy management for residential applications. It can charge its internal battery during off-peak periods when electricity is cheaper and discharge stored energy during peak-rate times to reduce electricity bills.

When used with the Gateway 2, the system enables full home backup during power outages by supplying critical, general, and smart loads. The Gateway 2 manages load prioritisation, generator integration, and grid connection based on user-defined settings.

When connected to the MPPT Unit, the system can receive energy from up to six high-power solar input channels. This supports flexible rooftop PV configurations and maximises solar energy harvesting throughout the day.

The system is scalable through the addition of one or more expansion batteries (up to 2 additional batteries), the total storage capacity increases. This allows the All in One to store more surplus energy and deliver extended power during outages or high-demand periods.

Together, these components form a modular smart energy platform that supports grid-tied, off-grid, and hybrid operation.

The following diagram shows an example smart home energy system using the All in One 2, MPPT Unit, and Gateway 2:

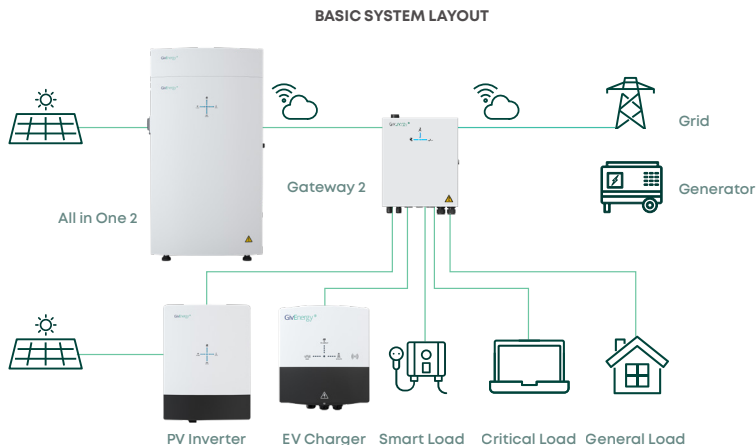

SYSTEM WITH EXPANSION BATTERIES AND MULTI-LOAD CONTROL

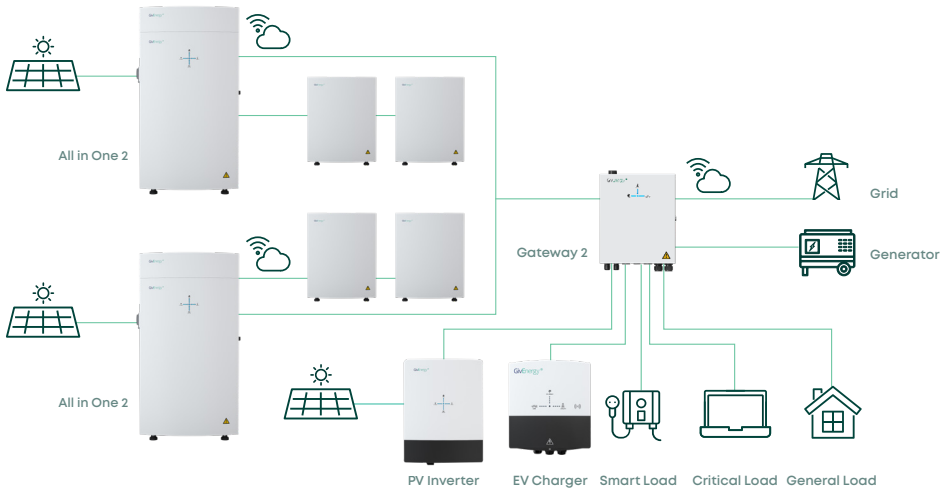

System Components

When used with Gateway 2, the system can form a multifunctional smart power system including:

- ✔ **PV Inverter:** The PV inverter can be connected to the system as an additional power generation device to make full use of clean energy. Excess energy can be charged to the AIO2 and even discharged to the grid to obtain maximum benefits.
- ✔ **Off-grid:** When AIO2 power is higher than 90%, will automatically turn off the output of the PV inverter. When AIO2 power is lower than 90%, AIO2 will turn on the output of the PV inverter again.
- ✔ **On-grid:** Excess energy can either charge the AIO2 or discharge to the grid. At this time, the AIO2 will not shut down the output of the PV inverter to maximize the benefits.
- ✔ **EV Charger:** The system can be connected to the household electric vehicle charger to monitor the charging status of electric vehicles in real time.
- ✔ **Generator:** A generator can connect as an extra power source. If the grid is off and the AIO2 power is low, Gateway 2 remotely starts the generator. The generator then powers the system and charges the AIO2. You can set a start state of charge (SOC) for the generator via the Gateway 2 server. If AIO2 power drops below this start SOC, Gateway 2 activates the generator. When the AIO2 battery reaches a "cut-off SOC", Gateway 2 stops the generator. Grid power always has priority; if the grid returns, Gateway 2 shuts down the generator. You can manually start the generator if grid power is off and the AIO2 battery is extremely low.



NOTICE

- ✔ A compatible remote-start generator is required for proper integration with the system.
- ✔ The PV inverter will not operate while the generator is running.

- **Smart Load:** Smart load is one of the household loads. It is recommended to access electrical equipment that consumes a relatively large amount of power and does not need continuous use, such as water heaters. When the system energy supply exceeds the demand, and energy begins to flow into the grid and is greater than 1kW, the smart load begins to work. The smart load will not stop working until the system energy demand is greater than the supply. When the smart load is required in an emergency, the Gateway 2 server provides the facility to forcibly enable or disable the smart load, ensuring that the load can be met at any time.
- **Critical Load:** Critical load is one of the household loads. It is recommended to access important electrical equipment that requires continuous use, such as network routers, computers, indoor lights, telephones, etc.. When the system has any power supply, the critical load will always be on, and the continuous and stable work of the important load will be guaranteed at all times. Note: This applies only if there is sufficient battery capacity available when off-grid.
- **General Load:** General load is one of the household loads. It is recommended to access electrical equipment that consumes a relatively large amount of power and is frequently used, such as air conditioning and heating equipment. General load will always be enabled while on-grid.
 - The Gateway 2 contains a bypass breaker, to force the load to connect with grid, to bypass the gateway. Only to be used when the system is not functioning.
 - **Off-grid:** When the AIO2 battery SOC is lower than the set value, the general load stops working until the SOC is higher than the set value. Reserving energy for the critical loads.
 - When the general load is required in an emergency, the Gateway 2 server provides the button to forcibly enable or disable the general load, ensuring that the load can be met at any time.

System Diagrams

The All in One 2 system supports various configurations. Each diagram below shows a different system layout based on connected components and use cases.

Single All in One 2 System Block Diagram

This configuration includes a standalone All in One 2 unit connected to the grid, a PV inverter, an EV charger, and load circuits via a switchboard.

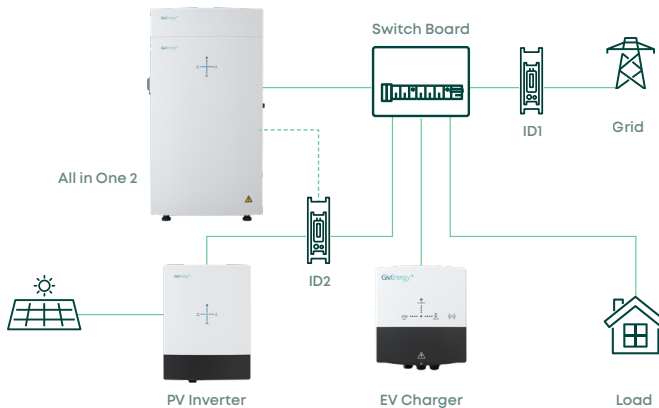

Single All in One 2 with MPPT Unit Block Diagram

This layout adds rooftop solar PV connected to the MPPT Unit, providing high-input solar capability.

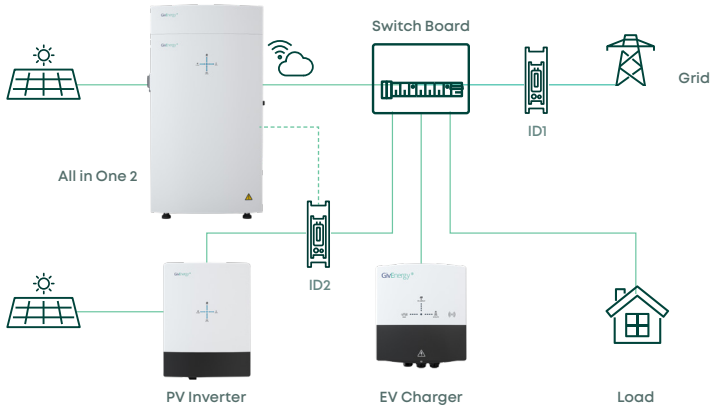

All in One with Gateway 2 System Block Diagram

This setup includes the Gateway 2 for managing smart, critical, and general loads. A generator and EV charger are also connected.

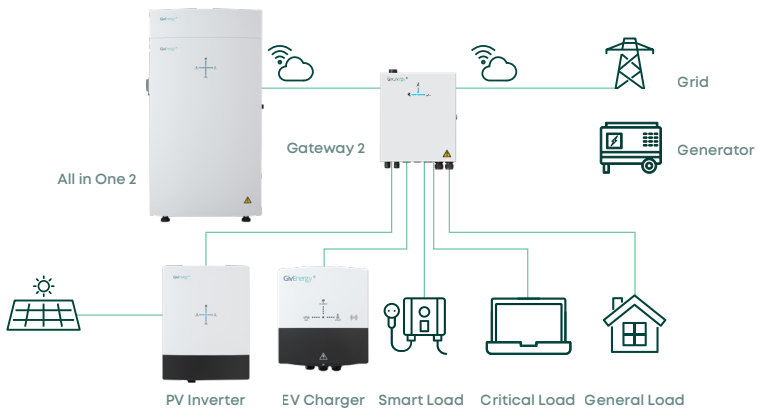

PRODUCT DESCRIPTION

All in One 2, MPPT Unit, and Gateway 2 System Block Diagram

This full-system layout shows All in One 2 connected to the MPPT Unit and Gateway 2. The system supports solar, generator, EV charging, and smart load management.

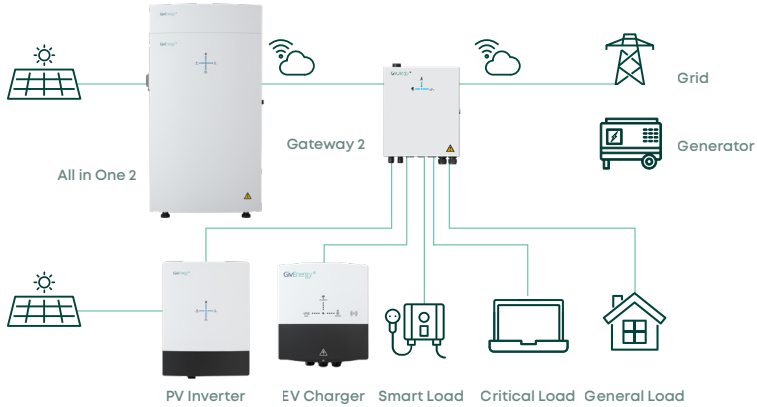

All in One 2

Interface Description

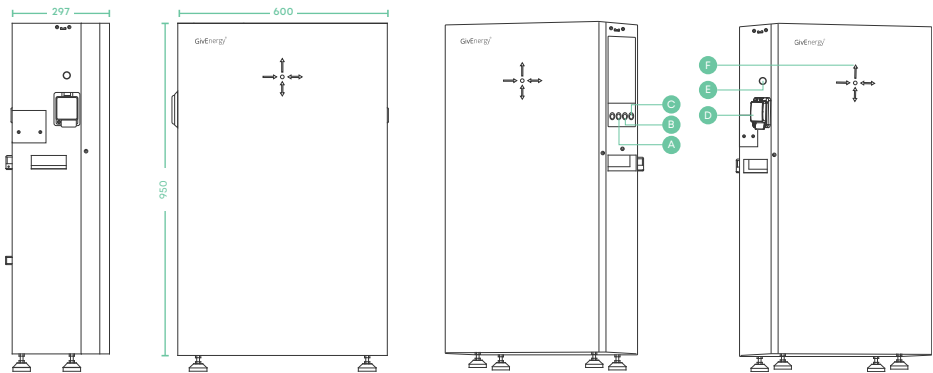

Item	Description	Item	Description
A	Communication Port	D	Battery Breaker
B	Reserved Port	E	All in One 2 Power Button
C	All in One AC Port	F	Front Panel LEDs

Specification

Model	GIV-AIO-AC-13.5-6.0	GIV-AIO-AC-13.5-8.0	GIV-AIO-AC-13.5-10.0	GIV-AIO-AC-13.5-11.0	GIV-AIO-AC-13.5-12.0
Internal Battery					
Battery Type	LFP				
Operating Voltage Range	260-346 Vd.c.				
Nominal Voltage	307.2 Vd.c.				
Max. Charging Current	25A				
Max. Discharging Current	41A				
Max. Charging Power	6000W (12000W with expansion)				
Max. Discharging Power	12600W				
Battery Capacity	13.5kWh				
Output Data (AC, On-Grid)					
Rated AC Output Power	6000W	8000W	10000W	11000W	12000W
Max. Apparent Power	6000VA	8000VA	10000VA	11000VA	12000VA
Nominal Off-Grid Power	12000VA	12000VA	12000VA	12000VA	12000VA
Peak Power (10s, Off-Grid)	14400VA				
Rated/Max. Output Current 26A	34.8A	43.5A	47.8A	52A	
Nominal Grid Voltage/Range	230 V.a.c (180 to 270V.a.c)				
Nominal Frequency/Range	50/60Hz; ±5Hz				
Power Factor (@Full Load)	>0.99				
Power Factor Range	0.8 lagging - 0.8 leading				
THDI (@Rated Power)	<3%				
AC Output Type	Single-Phase				
General Data					
Battery Max.Charging/Discharging Efficiency	96.5%				
PV Max. Efficiency	97.1%	97.1%	97.3%	97.3%	97.5%
Euro Efficiency	96.6%	96.6%	96.8%	96.8%	97.0%
MPPT Efficiency	99.9%				
Protection Degree	IP65				
Protection Class	Class I				
Overvoltage Category	PV: II, Battery: II, AC: III				
Inverter Topology	PV: Transformer-less; Battery: Transformer-less				

Specification

Model	GIV-AIO-AC-13.5-6.0	GIV-AIO-AC-13.5-8.0	GIV-AIO-AC-13.5-10.0	GIV-AIO-AC-13.5-11.0	GIV-AIO-AC-13.5-12.0
Noise Emission (Typical)	50dB				
Operation Temperature	-20°C ~ +50°C				
Relative Humidity	0~100%, Non-Condensing				
Altitude	4000m (Derating above 2000m)				
Dimensions (WxHxD)	600W*950H*280D (mm)				
Self-Consumption	<15W				
Number of Parallel Operation	2				
Display	LED & APP				
Communication	RS485/WIFI/4G Inside				
Warranty	15 Years				

Monitoring Data		
Radio Type	2.4G WiFi / BLE	
Frequency Range	2412-2472 MHz For WiFi 2402-2480 MHz For BLE	
Transmit Power (EIRP)	WiFi: 17.68 dBm (EIRP) BLE: 2.41 dBm (EIRP)	WiFi: 15.46 dBm (EIRP) BLE: 3.02 dBm (EIRP)
Radio Type	LTE/GNSS	
Frequency Range	Band 1: 1920-1980 MHz; Band 3: 1710-1785 MHz, Band 7: 2500-2570 MHz; Band 8: 880-915 MHz; Band 20: 832-862 MHz; Band 28: 703-748 MHz; GNSS: 1559-1610 MHz	
Transmit Power (EIRP)	LTE Band 1/3/7/8/20/28: 23 dBm	

Radiation Exposure Statement: This equipment complies with radiation exposure limits for uncontrolled environments. To ensure safety, it should be installed and operated with a minimum distance of 20 cm between the antenna and your body.

MPPT Unit

Interface Description

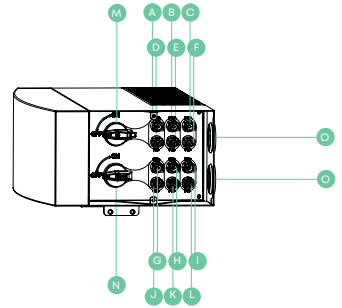

Item	Description	Item	Description
A	PV1+ Port	I	PV6+ Port
B	PV2+ Port	J	PV4- Port
C	PV3+ Port	K	PV5- Port
D	PV1- Port	L	PV6- Port
E	PV2- Port	M	PV1/2/3 Isolation
F	PV3- Port	N	PV4/5/6 Isolation
G	PV4+ Port	O	Grommet Port
H	PV5+ Port		

Specification

Model	GIV-MPP-20.0-G1
Input Data (PV)	
Max. DC Input Power	20,000W
Max. DC Input Power of Single MPP Tracker	4,500W
Start-up Voltage	60V
Max. PV Open-Circuit Voltage	600V
MPPT Voltage Range	80V-550V
Rated MPPT Voltage	360V
Max. Input Current	6*17A
Max. PV Short-Circuit Current	6*23A
MPP Tracker/No. of Strings per MPP Tracker	6/1
Dimensions (WxHxD)	600W*145H*280D (mm)

Expansion Battery

Interface Description

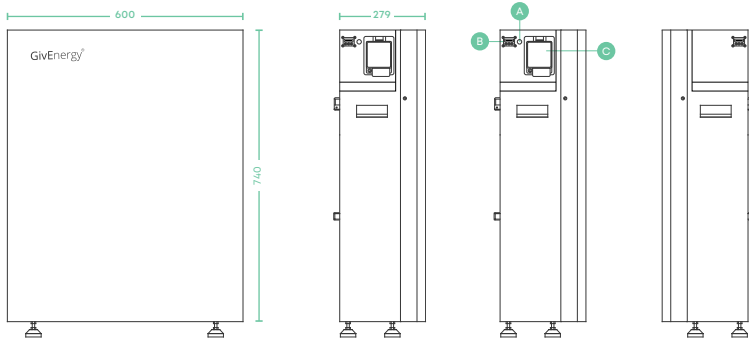

Item	Description
A	Expansion Battery Power Button
B	Expansion Battery Output Port
C	Expansion Battery Breaker

Specification

Model	GIV-BAT-13.5-AIO2-E
Battery Type	LFP
Operating Voltage Range	260~346 Vd.c.
Nominal Voltage	307.2 Vd.c.
Max. Charging Current	25A
Max. Discharging Current	41A
Rated Capacity	52Ah

Gateway 2

Interface Description

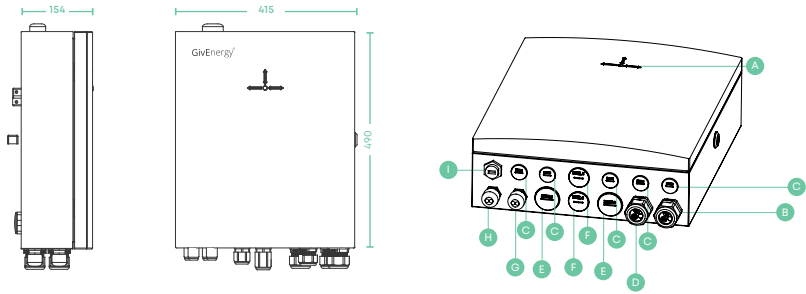

Item	Description	Item	Description
A	Gateway 2 Status Light	H	Communication Port
B	Grid Port	I	USB Port
C	M25 Wire Port		
D	General Load Port		
E	M32 Wire Port		
F	M40 Wire Port		
G	Communication Port		

Specification

Model	GIV-AIO-GW1-2
Grid Output AC	
Nominal AC Power	23,000W
Nominal AC Current	100A
Max. AC Current	100A
Rated Voltage	230V.a.c (180 to 270V.a.c)
Rated Grid Frequency	50/60±5Hz
Max. Output Fault Current	6000A
Max. Output Overcurrent Protection	100A

PRODUCT DESCRIPTION

Model	Gateway 2
General Load Output AC	
Nominal AC Power	23000W
Nominal AC Current	100A
Max. AC Current	100A
Rated Voltage	230V.a.c (180 to 270V.a.c)
Rated Grid Frequency	50/60±5Hz
Max. Output Fault Current	6000A
Max. Output Overcurrent Protection	100A
Critical Load Output AC	
Nominal AC Power	9200W
Nominal AC Current	40A
Max. AC Current	40A
Rated Voltage	230V.a.c (180 to 270V.a.c)
Rated Grid Frequency	50/60±5Hz
Max. Output Fault Current	6000A
Max. Output Overcurrent Protection	40A
Smart Load Output AC	
Nominal AC Power	9200W
Nominal AC Current	40A
Max. AC Current	40A
Rated Voltage	230V.a.c (180 to 270V.a.c)
Rated Grid Frequency	50/60±5Hz
Max. Output Fault Current	6000A
Max. Output Overcurrent Protection	40A
Generator Input AC	
Nominal AC Power	9200W
Nominal AC Current	90A
Max. AC Current	90A
Rated Voltage	230V.a.c (180 to 270V.a.c)
Rated Grid Frequency	50/60±5Hz
Max. Output Fault Current	6000A
Max. Output Overcurrent Protection	90A

PRODUCT DESCRIPTION

Model	Gateway 2
EV Charger Output AC	
Nominal AC Power	7200W
Nominal AC Current	32A
Max. AC Current	32A
Rated Voltage	230V.a.c (180 to 270V.a.c)
Rated Frequency	50/60±5Hz
Max. Output Fault Current	6000A
Max. Output Overcurrent Protection	32A
AIO 2 Input AC	
Nominal AC Current	52A
Max. AC Current	52A
Rated Voltage	230V.a.c (180 to 270V.a.c)
Rated Frequency	50/60±5Hz
PV Input AC	
Nominal AC Current	43A
Max. AC Current	43A
Rated Voltage	230V.a.c (180 to 270V.a.c)
Rated Frequency	50/60±5Hz
AIO 2 Parallel Input AC	
Nominal AC Current	52A
Max. AC Current	52A
Rated Voltage	230V.a.c (180 to 270V.a.c)
Rated Frequency	50/60±5Hz
General Data	
Dimensions	380Wx460Hx150D (mm)
Protective Class	Class I
Operating Temperature Range	-20 ~ +50°C
Ingress Protection	IP65

Model	Gateway 2	
Monitoring Data		
Radio Type	2.4G WiFi / BLE	
Frequency Range	2412-2472 MHz For WiFi 2402-2480 MHz For BLE	
Transmit Power (EIRP)	WiFi: 17.68 dBm (EIRP) BLE: 2.41 dBm (EIRP)	WiFi: 15.46 dBm (EIRP) BLE: 3.02 dBm (EIRP)
Radio Type	LTE/GNSS	
Frequency Range	Band 1: 1920-1980 MHz; Band 3: 1710-1785MHz, Band 7: 2500-2570 MHz; Band 8: 880-915 MHz; Band 20: 832-862 MHz; Band 28: 703-748 MHz; GNSS: 1559-1610 MHz	
Transmit Power (EIRP)	LTE Band 1/3/7/8/20/28: 23 dBm	

Key Features

- ✔ It supports multiple scenarios: grid-connected, off-grid, and pure off-grid. It also supports multiple working modes like spontaneous self-use (ECO Mode), Time of Use (TOU), and requires full internet access for app integration.
- ✔ Users can query the total discharge information of the product's life cycle in real time.
- ✔ It provides intelligent operation and is simple to setup and configure.
- ✔ It has built-in Wi-Fi and 4G for integrated connectivity.
- ✔ It operates independently with single-phase output to accommodate irregular load changes.
- ✔ It allows real-time adjustment of spontaneous self-consumption. You have full control of the output grid power.
- ✔ Modular terminals for system connections make installation and removal of individual components easier.
- ✔ The supporting battery has a modular design. You can freely match battery capacity.
- ✔ One person can install and operate the system.
- ✔ The factory settings meet the default settings of the main target market. Power can be generated by simply connecting the AC side and switching it on (Black Start)
- ✔ An LED display shows the real-time working status. You can use a mobile phone APP to control the system remotely.

Inverter Operating Modes

The inverter has several operating modes. The machine performs self-tests when first powered on. After the self-tests are normal, it enters an operating mode. The system will switch between modes and enter a standby state when a mode's operation ends.

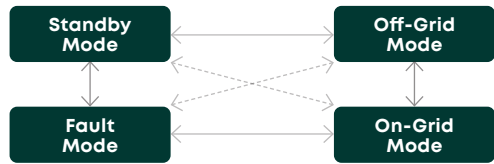

Item	Specification	Description
1	Standby Mode	<p>The inverter is powered on but not actively charging or discharging.</p> <ul style="list-style-type: none"> Performs internal self-tests during initial power-up. Waits in standby until system conditions allow transition to another mode. Automatically enters standby when grid or battery conditions are not met.
2	On-Grid Mode	<p>The inverter is connected to the utility grid and operating normally.</p> <ul style="list-style-type: none"> Supplies power to the grid and/or household loads. Switches to Off-Grid Mode automatically if the grid becomes unstable or disconnects. If a system fault occurs, switches to Fault Mode and stops operation. If grid conditions fall outside of acceptable limits and off-grid is unavailable, the inverter returns to Standby Mode.
3	Off-Grid Mode	<p>The inverter operates independently of the utility grid using battery and solar energy.</p> <ul style="list-style-type: none"> Automatically enables Emergency Power Supply (EPS) outputs. If a fault occurs, switches to Fault Mode and stops operation. When the grid returns and passes self-check, the inverter switches to Standby Mode, then transitions to On-Grid Mode. If battery power is insufficient or off-grid requirements are not met, returns to Standby Mode.
4	Fault Mode	<p>The inverter detects a fault and stops all operation to protect the system.</p> <ul style="list-style-type: none"> Displays an error message identifying the fault. Performs self-diagnostics while in standby. Remains in standby until the issue is resolved and the system is ready to resume normal operation.

Main Work Modes

Daytime Mode

During daylight hours, the MPPT Unit receives energy from connected photovoltaic (PV) panels. The system prioritises energy usage in the following order:

- Supplies power to household loads.
- Charges the battery with surplus solar energy.
- Exports any remaining energy to the grid.

If the grid is unavailable, the generator can start automatically to power the system and recharge the battery if required.

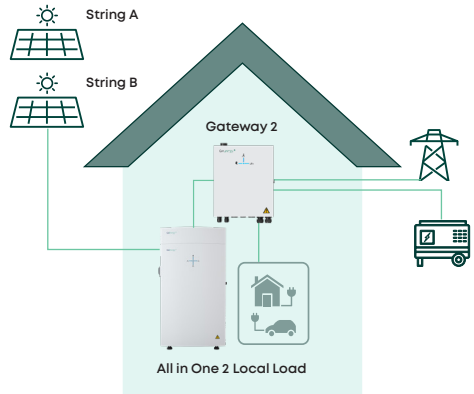

Night-time Mode

During evening and night-time hours, the system discharges the battery to supply household loads, reducing reliance on the grid during peak electricity pricing. If needed, the battery may recharge during off-peak hours when tariffs are lowest.

If the battery is fully discharged, the system automatically switches to grid power. In the event of a grid outage, the generator can be started to power the home and recharge the battery.

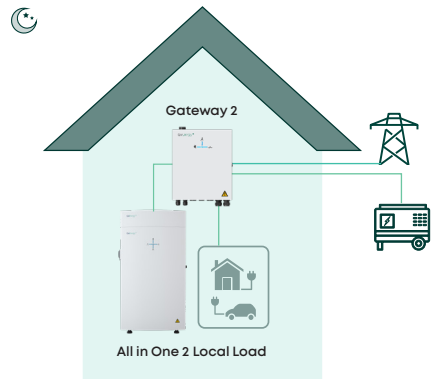

Island Mode

The system can operate as an independent power system in island mode.

It can also be used as a backup power system if there is a power outage.

If there is no solar energy at this time, the generator can be started to power the entire household load. The generator can also charge the battery.

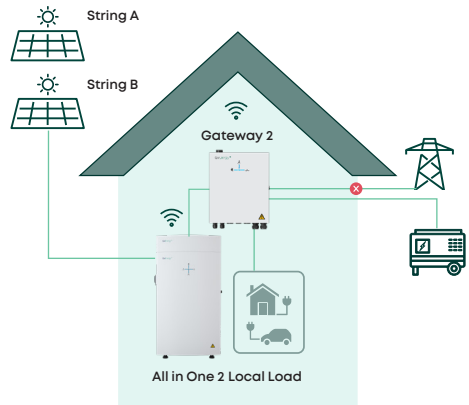

Demand Response Mode (External Control by Grid supplier)

The system has a function for remote data collection and analysis. This can provide users with real-time information about the working situation of the entire system. If necessary, the system can also be controlled remotely to meet daily needs.

This mode requires integration with your chosen grid supplier that supports Grid Services

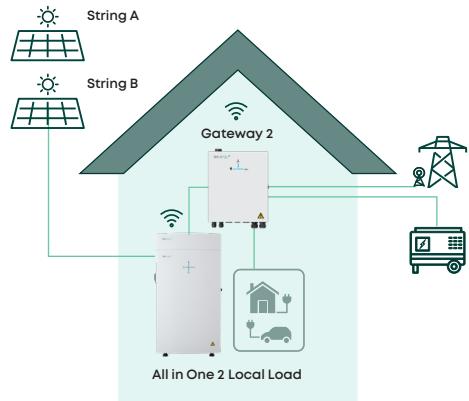

Unpacking Inspection

When you unpack the system, please check the following items:

- ✔ Ensure there are no missing accessories from the packaging list.
- ✔ Confirm the model and specification of the All in One, MPPT Unit, and Gateway1-2 nameplates match your order specifications.
- ✔ Make sure the packaging and product are free from any damage.

If any damage to the packaging is visible, or if you find that the unit is damaged after unpacking, please notify the distributor immediately. If anything is damaged or missing, please contact your supplier.

Do not dispose of the original packaging. If you need to transport the unit, it is better to store it in the original packaging.

Packaging List

All in One 2

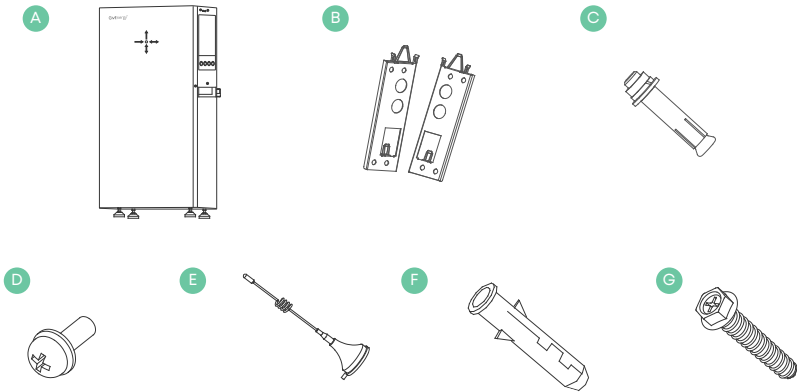

Item	Description	Amount
A	All in One	1
B	Wall Rack	2
C	Concrete Anchor	4
D	Safety Screw (Anti-Theft)	2
E	Antenna is Integral	1
F	Rawl Plug	4
G	Tapping Screw Coach Screw	4

Gateway 2

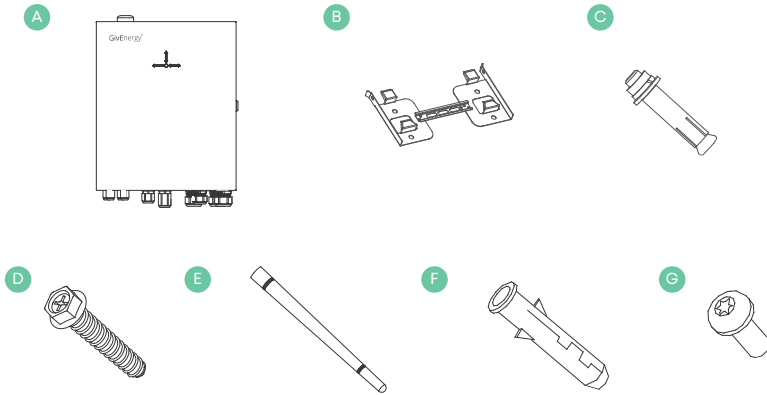

Item	Description	Amount
A	Gateway 2	1
B	Wall Rack	1
C	Concrete Anchor	4
D	Coach Screw	4
E	WiFi Antenna	1
F	Rawl Plug	4
G	Torx Screw (Anti-Theft)	2

MPPT Unit

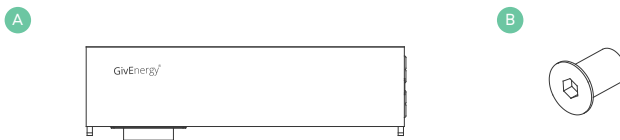

Item	Description	Amount
A	MPPT Unit	1
B	Stainless Screw	6

Safety Instructions



DANGER - Risk of Death Due To Fire or Explosion.

- ✔ Electrical devices can cause fires.
- ✔ Install Inverter on a non-flammable surface
- ✔ Do not install the inverter where flammable materials are stored.



WARNING - Risk of Burns Due To Hot Enclosure Parts.

- ✔ The inverter can become very hot during operation. Mount the inverter in a suitable location.
- ✔ Do not touch the heat sink at the back of the Inverter or nearby surfaces while the Inverter is operating. Wait for the Inverter to cool down before handling.



CAUTION - Equipment Damage and Operational Risks.

- ✔ All electrical installations must be done according to local wiring regulations (e.g BS7671 in UK).
- ✔ Do not remove the casing. The inverter contains no user serviceable parts. Only qualified service personnel should perform servicing.
- ✔ All wiring and electrical installation should only be done by a qualified electrician.
- ✔ Carefully remove the unit from its packaging. Inspect it for external damage. If you find any damage, contact your local supplier immediately.
- ✔ The MPPT unit shall only be used with PV generation sources. Wind, hydro etc. should be AC coupled via the Gateway.
- ✔ This unit is designed to feed power to the public power grid (utility) only.
- ✔ Do not connect this unit directly to a generator unless specified by other system components like the Gateway 2.
- ✔ Connecting the inverter incorrectly to external devices could seriously damage your equipment.



NOTICE - Important Safety Information Regarding Voltage.

- ✔ Both AC and DC voltage sources are terminated inside the MPPT Unit. Always disconnect these circuits before servicing.
- ✔ When a photovoltaic panel is exposed to light, it generates a DC voltage.
- ✔ When connected to this equipment, a photovoltaic panel will charge the DC capacitors. Which will remain charged long after the source is removed.
- ✔ Energy stored in this equipment's DC capacitors presents a risk of electric shock. Even after the unit is disconnected from the grid and photovoltaic panels, high voltages may still exist inside the PV-Inverter.

Mounting Area

Follow these recommendations when choosing an installation location:

- ✔ Do not install the product where it can come into direct contact with water or direct sunlight.
- ✔ The location must be able to support the weight and size of the inverter.
- ✔ Choose a location where you can easily see the product status display.
- ✔ Do not install the product on structures made of flammable or explosive materials.
- ✔ The humidity of the installation location should be between 0-95%, with no condensation.
- ✔ The installation location must be safely accessible at all times.
- ✔ Do not place anything on top of the product. This can cover the product and prevent proper cooling.
- ✔ Do not install the product near a TV antenna or any other antenna or antenna cable. To minimize the risk of interference.
- ✔ The product needs enough space for cooling. This provides good ventilation and ensures heat can be lost effectively.
- ✔ The surrounding air temperature should be below 40°C for the best operation.
- ✔ When mounted, the product should be installed vertically, perpendicular to the horizontal ground.

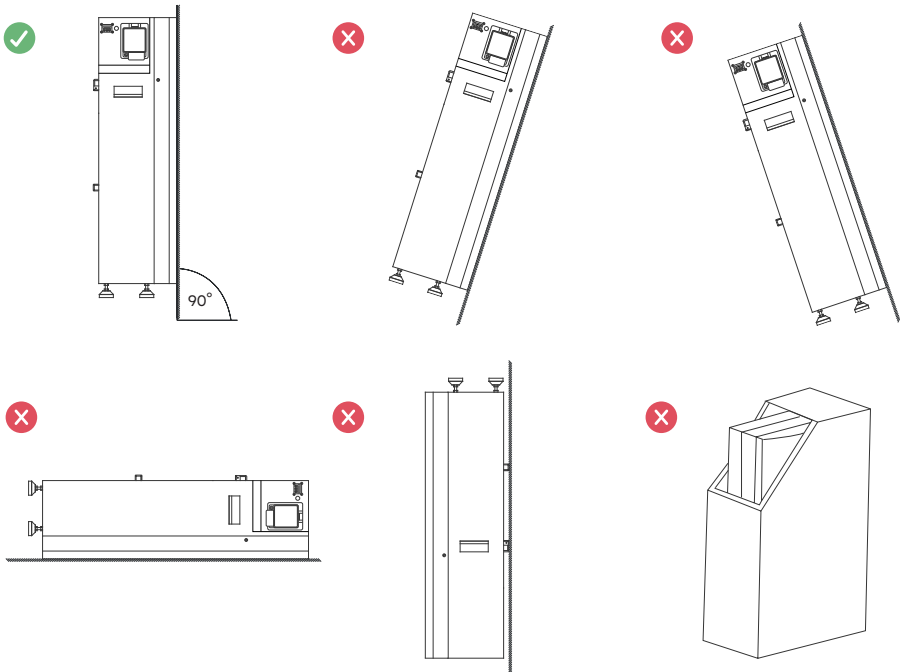

Minimum Clearance

Please ensure that the All in One 2 meets the following clearance criteria:

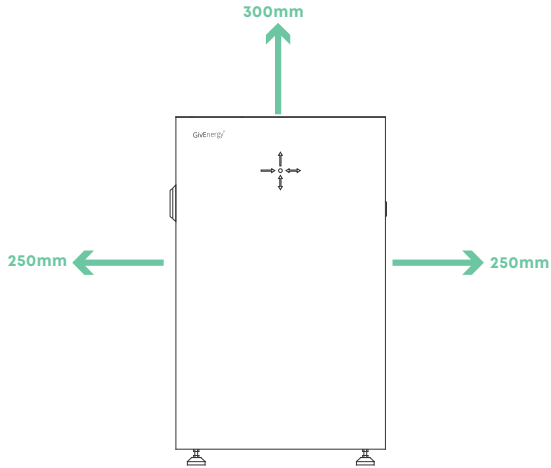

Installation Procedure

All in One 2 and MPPT Unit (Desk)

Step 1: The wall must be at least 120mm deep. Use the support bracket as a template to mark the positions for drilling holes.

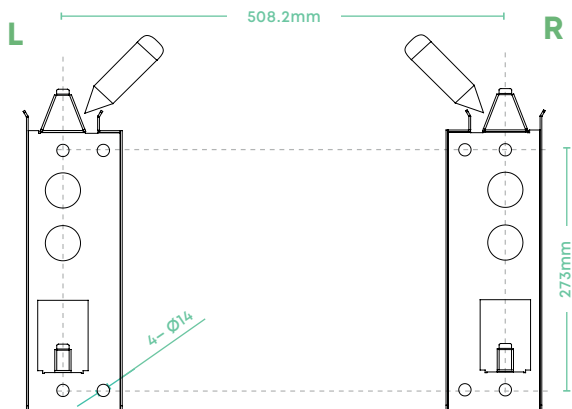

Step 2: Drill holes to a depth of at least 75mm. Hammer the expansion bolts into the holes. Fix the support bracket to the wall using the expansion bolts. Use appropriate fixings for the construction type.

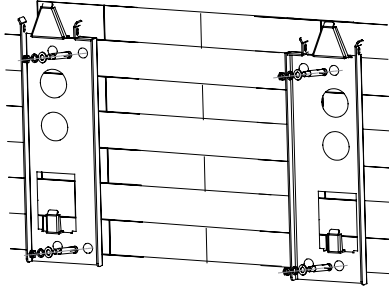

Step 3: Open the All in One 2 packing case. Take out the battery module.

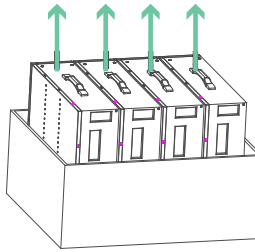

Step 4: Mount the All in One 2 unit onto the wall mount bracket. Please note, the All in One 2 can be wall mounted or floor standing but either configuration requires the bracket.

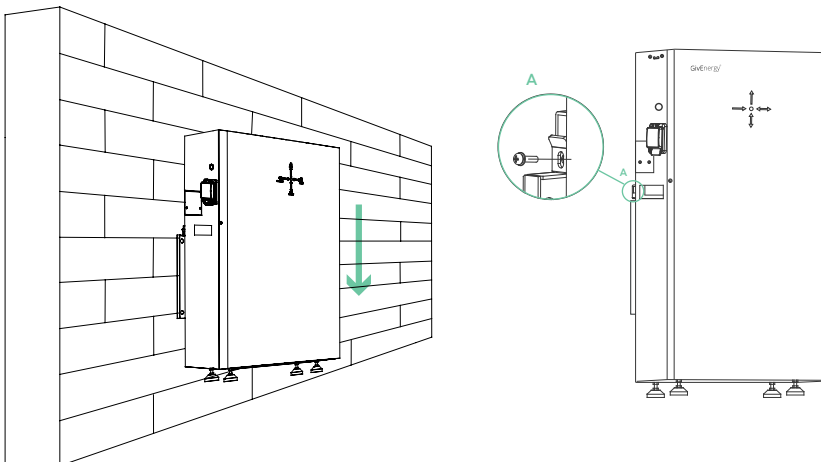

Step 5: Adjust the height of the support feet. Ensure that the top surface of the All in One 2 is level.

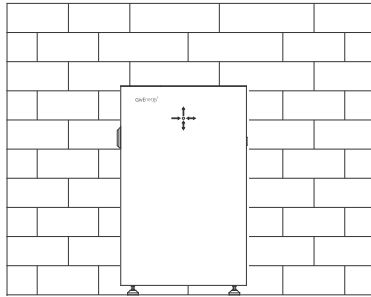

Step 6: Insert the battery module into the chassis of the All in One 2 battery compartment and install the internal battery front cover.

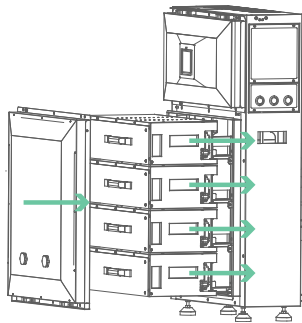

Step 7: Screw the front cover into place, ensuring it is fitted correctly so the LEDs can be seen correctly.

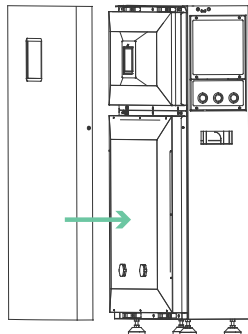

Step 8: Place the MPPT Unit on top of the All in One 2 unit.

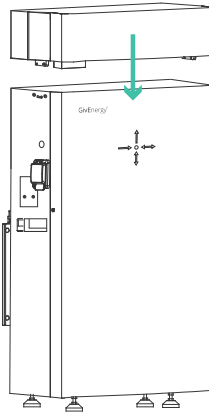

Step 9: Fasten the MPPT Unit to the All in One 2 unit using screws.

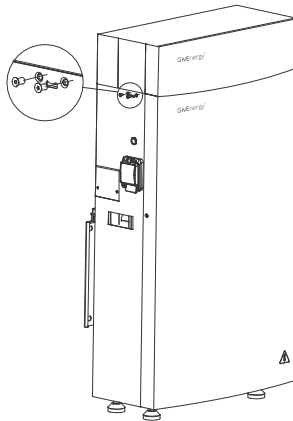

Step 4: Fasten the Gateway 2 to the support bracket using screws. Ensure you leave enough space around the gateway unit for heat dissipation.

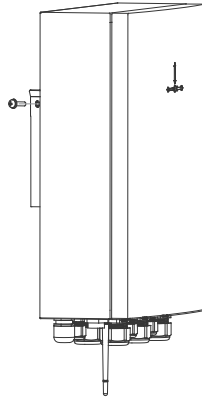

Electrical Connection

Inverter AC Connection

- The output power cable of the All in One 2 should be at least 10mm². Strip the insulation layer of the cable by 12mm. Route the power cable through the waterproof gland. Then, connect it to the AC Input WAGO block.
- PV power cables should be at least 4mm². For longer runs, use 6 mm² to reduce voltage drop.
- The cable length should not exceed 50m. The resistance of a longer cable will consume power and reduce the efficiency of the product.

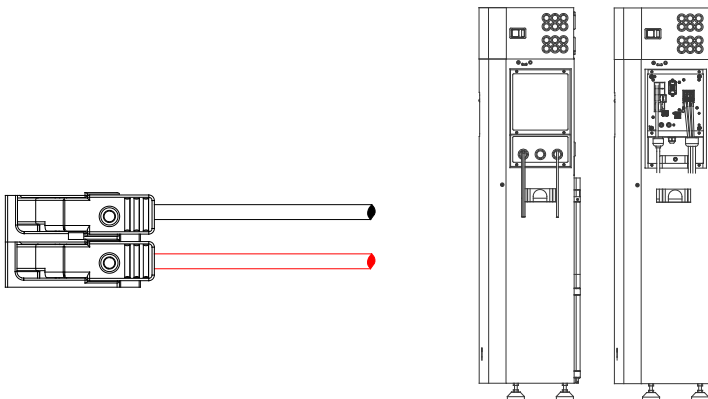

Gateway 2 AC Connection

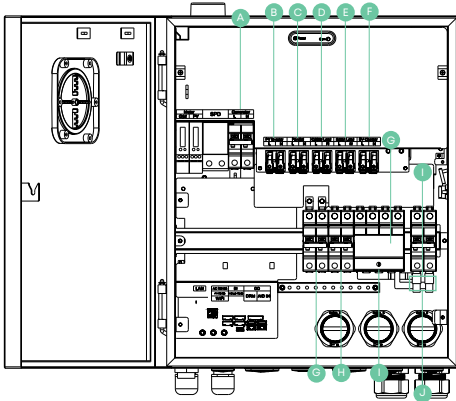

Item	Description
A	Generator Connection
B	PV Inverter Connection
C	Parallel Connection
D	Critical Load
E	Smart Load
F	EV Charger
G	All in One Connection
H	General Load Connection
I	Bypass Breaker
J	Grid Connection

A - Generator Connection

- The power cable specifications of the generator are determined by the output power of the generator.
- Connect the generator to the generator WAGO via a suitable over current protection device (not supplied); Max 32A

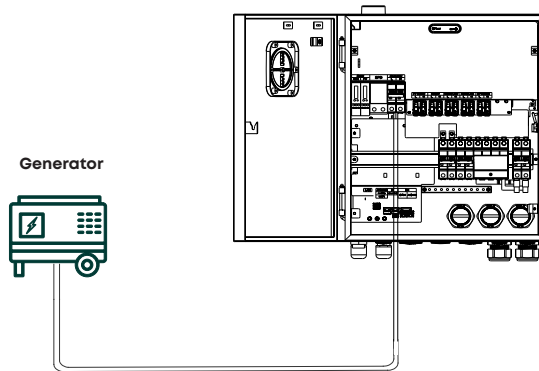

B - PV Inverter Connection

- ✔ The power cable specifications of the PV inverter are determined by the output power of the PV inverter.
- ✔ Connect the PV Inverter via a suitable overcurrent device to the WAGO marked PV Inverter.

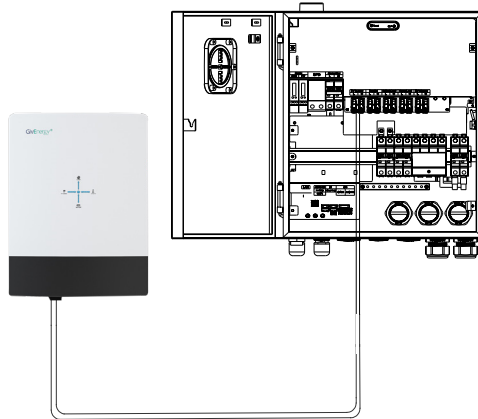

C - Parallel Connection

- ✔ Up to 3× AIOs can be paralleled via the Gateway; connect each AIO to the Gateway with its own AC feed and RJ45 comms.
- ✔ Use either Gateway external tails or internal RCBOs (C32, bi-directional) for protection; ensure all AIOs run matching D612-A612 firmware and Gateway v10+ before commissioning.

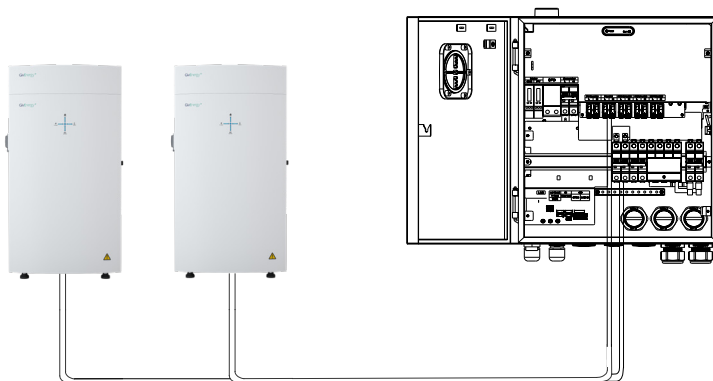

D - Critical Load Connection

- ✔ The power cable for the critical load should be suitably sized based on the connected load and the overcurrent protection device used.
- ✔ The critical load should be connected to the marked WAGO via the overcurrent device (Not supplied) – Max 32A.

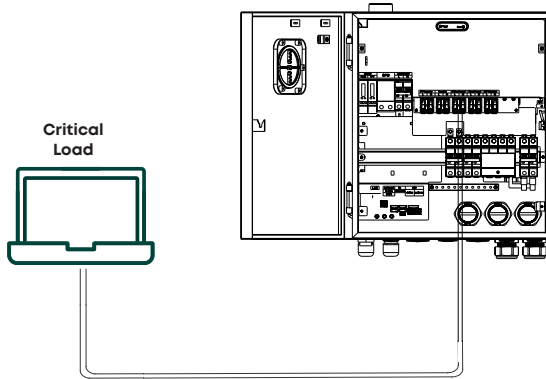

E - Smart Load

- ✔ The power cable for the smart load should be suitably sized according to the connected load and the overcurrent protection used.
- ✔ The smart load shall be connected to the WAGO marked Smart Load, via a suitable sized over current protection (Not supplied) – Max 32A.

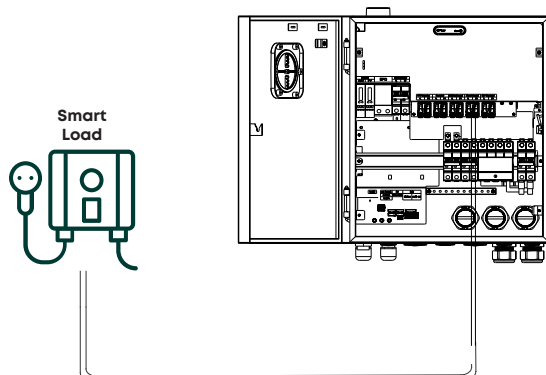

F - EV Charger

- Connect the EV charger from a 40A Type A 30 mA RCD to the grid busbar using 6 mm² (or larger) cable; ensure the grid breaker is isolated before work.
- Please ensure that you fit the correct over current and residual current protection for the circuit inline with local wiring regulations.

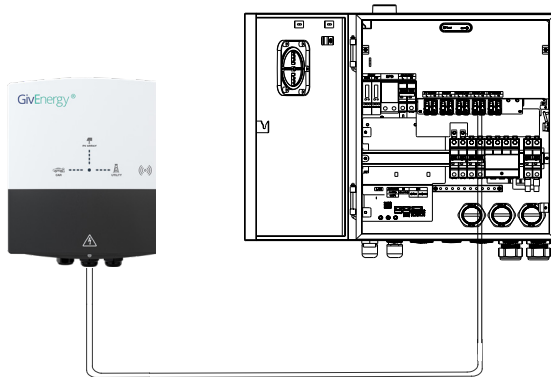

G - All in One Connection

- Connect the AC supply from the All in One to the Gateway using the lower AC terminals; remove the bottom cover before wiring and replace once complete.
- Connect the communication cable from the All in One to the Gateway comms port as shown, ensuring correct routing through the lower entry points (detailed in Communication Connection).

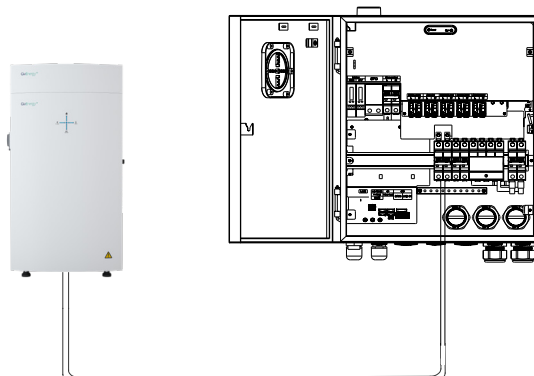

H - General Load Connection

- ▶ The general load power cable should be at least 16mm typically 25mm fed via a suitable over current device.

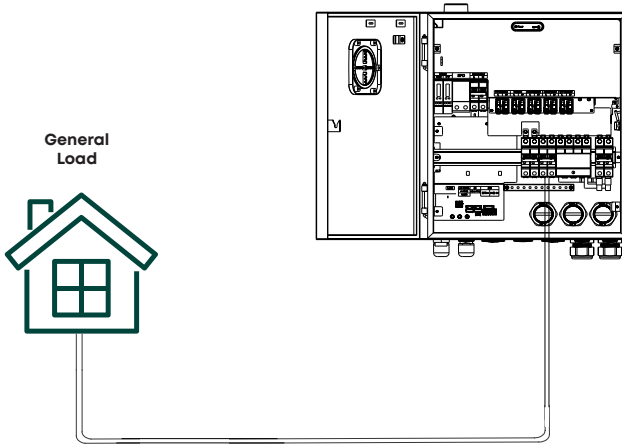

H i) - General Load Connection Configuration

- ▶ General load can be configured to split essential backup loads powered through the Gateway 2 during outages, while non-essential loads remain connected to the main meter and are not backed up.

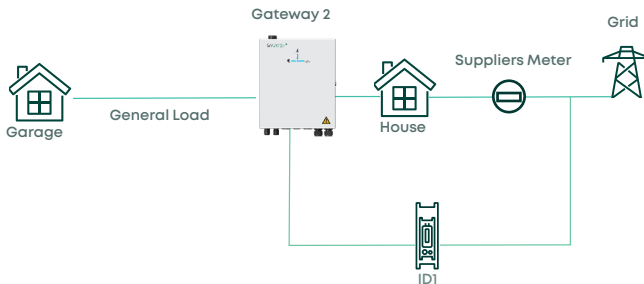

J - Grid Connection

- The grid power cable should be at least 25mm².
- Connect the grid supply to the supplied C100 breaker. Ensuring correct polarity is observed.

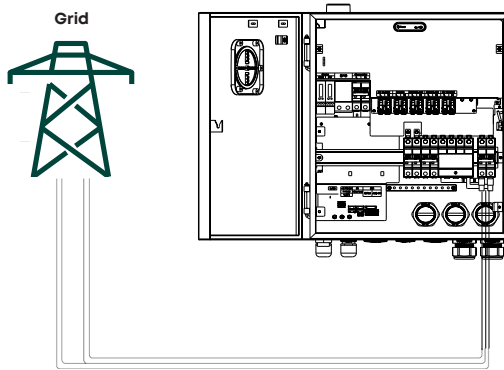

Communication Connection

System Communication Connection

- Connect the All in One 2 to Gateway communication cable to their respective ports using a fully wired screened RJ45 cable.
- Communication with the portal can be either 4G, WiFi or LAN.

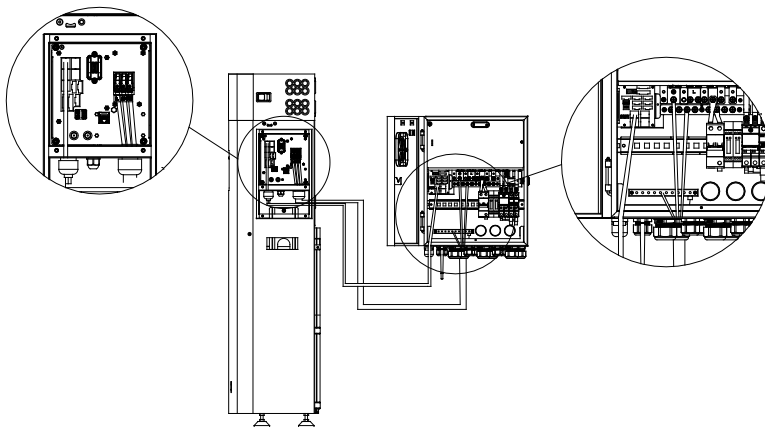

Gateway 2 Communication Port

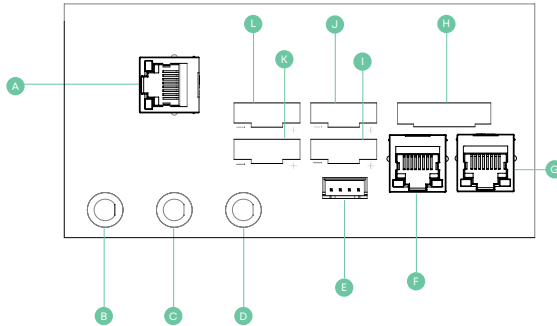

Item	Function	Foot Position	Note
A	LAN Port	Standard RJ45 Port	
B	GPS Port	Antenna Connector	
C	4G Port	Antenna Connector	
D	WiFi Port	Antenna Connector	
E	USB Extension Port	Four Pin Connector	
F	DRM Port	RJ45 Port for DRM	
G	All in One Port	RJ45 Port for AIO	
H	DO1 Port	1:DO1+ 2:DO1-	Digital Output Port
I	Debug Port		
J	DI1	1:DI1+ 2:DI1-	Digital Input Port
K	PV RS485	ID1 Meter	
L	AC RS485	ID2 Meter	ID3-8 can also be connected here

All in One 2 Communication Port

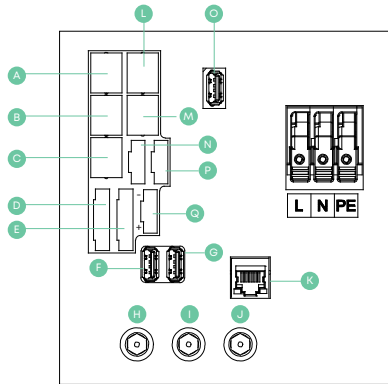

Item	Function	Foot Position	Note
A	Gateway Network Cable Port	Standard RJ45 Port	Gateway Communication Interface
B	Parallel In Port		Single All in One does not use this
C	DRM Port	RJ45 Port for DRM	
D	DO1 and DO2 Output Port	1:DO1+ 2:DO1- 3:DO2+ 4:DO2-	Digital Output Ports
E	DI1 and DI2 Input Port	1:DI1+ 2:DI1- 3:DI2+ 4:DI2-	Digital Input Ports
F	BCU USB		
G	LCD USB		Future Use
H	4G Antenna Port	Antenna Connector	
I	WiFi Antenna Port	Antenna Connector	
J	GPS Antenna Port	Antenna Connector	
K	LAN Port	Standard RJ45 Port	
L	Gateway Out Port		Single All in One does not use this
M	Parallel Out Port		Single All in One does not use this
N	485 Port		
O	Inverter Firmware Port	Standard USB Port	Single All in One does not use this
P	User C		
Q	RS485	ID1-8 Meter	For Gateway-less installations

Wireless Connectivity

The All in One 2 uses a combination of 4G and WiFi as standard wireless communication. The inverter comes with internal Wi-Fi wireless communication and 4G modem. During set-up, the unit will default to 4G for set-up, with WiFi setup during commissioning. You can connect the corresponding communication connection to the monitoring server for real-time data monitoring and inverter control. For specifics, refer to the Wi-Fi configuration instructions or consult your installation supplier.

You may if required connect external antenna to these ports (not supplied).

DRM (Demand Response Management)

When the inverter is used in Australia, it needs to connect to a DRMS (Demand Response Management System) device. Connect the DRMS device to the DRM terminal of the inverter to run.

The RJ45 terminal is defined as follows:

Pin	DRMS	Pin	DRMS
Pin1 (Orange-White)	DRM1/5	Pin5 (Blue-White)	Ref/Gen
Pin2 (Orange)	DRM2/6	Pin6 (Green)	GND
Pin3 (Green-White)	DRM3/7	Pin7 (Brown-White)	/
Pin4 (Blue)	DRM4/8	Pin8 (Brown)	/

Inverter demand response modes:

Mode	RJ45 Pins to be Connected	Demand
DRM0	Connect Pin5 and Pin6	Stop
DRM1	Connect Pin1 and Pin5	Disallow charge
DRM2	Connect Pin2 and Pin5	Charge power should be less than 50% of the rated power
DRM3	Connect Pin3 and Pin5	Charge power should be less than 75% of the rated power
DRM4	Connect Pin4 and Pin5	Charge power should be less than 100% of the rated power
DRM5	Connect Pin1 and Pin5	Disallow discharge
DRM6	Connect Pin2 and Pin5	Discharge power should be less than 50% of the rated power
DRM7	Connect Pin3 and Pin5	Discharge power should be less than 75% of the rated power
DRM8	Connect Pin4 and Pin5	Discharge power should be less than 100% of the rated power

System commissioning is a critical phase that ensures the All in One 2 system and its associated components are correctly configured and verified for safe and optimal operation before going live. This process must be performed by a qualified technician using the designated engineering software.



CAUTION - Commissioning Required

- ✔ The inverter will not operate correctly or safely if the commissioning procedure is skipped or incomplete.
- ✔ Incorrect parameter settings can lead to system malfunction, inefficient operation, or potential damage to the equipment or connected battery system.

Pre-Commissioning Checks

Before initiating the software-based commissioning steps, conduct a thorough physical inspection and verification:

- ✔ **Wiring:** Check that all DC (PV, battery) and AC (grid, loads) wires are secure, correctly polarized, and match design plans. Look for loose connections or damaged insulation.
- ✔ **Components:** Ensure all parts (All in One 2, MPPT Unit, Gateway 2, battery, breakers) are correctly installed and undamaged.
- ✔ **Earthing:** Verify all components are correctly earthed.
- ✔ **PV Array:**
 - ✔ Confirm PV string voltage (Voc) and current (Isc) are within limits for the All in One 2 and MPPT Unit.
 - ✔ Ensure PV strings connect to the correct MPPT inputs. Observing correct polarity
 - ✔ Ensure the PV Isolator(s) are switched on.
- ✔ **Battery:**
 - ✔ Ensure any external battery expansion modules are correctly connected and switched on.
- ✔ **AC Supply:** Ensure grid voltage and frequency are within the inverter's allowed range. Ensure the isolator is ON.

System Startup and Shutdown



WARNING - High Voltage Risk

- ✔ The inverter will generate high voltage inside after opening.
- ✔ Do not touch the internal wiring position of the machine after power-on. This is to prevent electric shock that can cause personal injury.

Start-Up the Inverter

Follow these steps to start the inverter:

1. Switch on the AC circuit breaker.
2. Turn on the PV DC switch(s). Note there are 2 of them in the MPPT module (1-3 & 4-6)
3. Turn on the battery breaker. Including expansion packs
4. The inverter will start automatically if all the following conditions are met:
 - ✔ The PV voltage is higher than 80V on at least one string.
 - ✔ The battery voltage is higher than 254.4V.
 - ✔ The AC supply is switched on.

Disconnect the Inverter (Shutdown)

Follow these steps to shut down the inverter:

1. Disconnect the AC circuit breaker to prevent it from being reactivated.
2. Disconnect the Battery breaker to prevent it from being reactivated.
3. Turn off the PV switch(s).
4. Check the inverter operating status. It may remain on for up to 5 mins
5. Wait until the LED display has gone out; the inverter is now shut down.

Equipment Parameter Setting and Monitoring

You can perform the following operations for the inverter using the designated software or monitoring platforms:

- ✔ View the running data, software version, and alarm information of the device.
- ✔ Set the equipment parameters, such as power grid parameters, communication parameters.
- ✔ Maintain the equipment.
- ✔ Upgrade the device software version.

System Power-Off for Maintenance

Before performing any maintenance, you must completely power off the system:

1. Disconnect the AC circuit breaker to prevent it from reactivating.
2. Disconnect the battery circuit breaker to prevent it from reactivating.
3. Turn off the photovoltaic (PV) switch(s).
4. Check the operating status of the inverter.
5. Wait until the LED display goes out and the inverter turns off.



CAUTION - Ensure System is Fully switched off and Cool

- ✔ It is necessary to wait for more than 20 minutes after shutdown. Especially if the inverter is hot
- ✔ This confirms that the inverter is completely powered off and the surface temperature has cooled before you perform any other actions on the machine.

Regular Maintenance

✔ Checking Heat Dissipation

If the inverter regularly reduces its output power due to high temperatures, please improve the heat dissipation conditions. You may need to clean the heat sink or check for other obstructions that block airflow. Check the area for debris and accumulated dust.

✔ Cleaning the Inverter

If the inverter is dirty, please shut down the inverter completely as described previously. Then, clean the enclosure lid. Use a soft, dry cloth. If necessary, you can use a slightly damp cloth. Do not use harsh chemicals or abrasive cleaners.

✔ Checking the DC switch

Check for externally visible damage and discoloration of the DC breaker and its cables at regular intervals. If there are any signs of visible damage to the breaker, or visible discoloration or damage to the cables, contact the installer immediately.



NOTICE - Maintain DC Switch Contacts

- ✔ Once a year, turn the rotary switch of the DC switch from the On position to the Off position 5 times in succession.
- ✔ This cleans the contacts of the rotary switch and prolongs the electrical endurance of the DC isolator.

✔ Fan Maintenance

Inspect the fan for dust, noise, or obstructions. Clean gently using a soft brush or compressed air. Do not use liquids. Replace if faulty.

GivEnergy products undergo strict testing and inspection before delivery to ensure high performance and reliability. However, as with all electrical devices, issues may still occur.

If you experience any problems, visit www.givenergy.co.uk check the Q&A section, or contact GivEnergy Customer Support for further assistance.

To ensure a quick and efficient resolution, please have the following details ready when contacting support:

1. **Product Serial Number(s):** Located on the product label(s) of the All in One 2 and any connected GivEnergy components (e.g., MPPT Unit, Gateway 2).
2. **Error Code or System Message:** Note any error codes or messages displayed on the unit or in the monitoring app.
3. **Installation Date and Details:** Include the date of installation and basic system configuration.
4. **Description of the Issue:** Clearly explain the problem, when it started, and how it affects system operation.
5. **System Readings (if safely accessible):**
 - ✔ Battery Voltage
 - ✔ Grid Voltage and Frequency
 - ✔ PV Voltage (if applicable)
6. **Time of Fault Occurrence:** Note the specific date and time when the issue first appeared or typically occurs.
7. **Reproducibility:** Can you reliably recreate the issue, or does it happen randomly?
8. **Recent Changes:** Note any recent changes to the system, electrical setup, or significant weather events.

This section provides suggestions for common faults.

No.	Fault Name	Reason of Fault	Handling Suggestions
1	Inverter NTC Fault	The inverter's working environment temperature is too high or too low.	<p>If temperature is too high: Lower the ambient temperature or turn off the inverter for 15 minutes, then restart. Ensure installation follows the user manual guidelines.</p> <p>If temperature is too low: Do not attempt to start the inverter. Contact after-sales service immediately.</p>
2	Grid Frequency Fault	The inverter detects that the grid frequency is outside the normal range specified by safety regulations.	<p>Verify that the Grid Code (Grid Safety Standard) is correctly configured.</p> <p>Check if the AC frequency (Freq) is within the acceptable range.</p> <p>If the issue is rare and resolves quickly, it may be due to occasional grid instability.</p>

No.	Fault Name	Reason of Fault	Handling Suggestions
3	Grid Voltage Fault	The inverter detects that the AC voltage is outside the normal range required by safety regulations.	<p>Make sure the safety country setting of the inverter is correct.</p> <p>Use a multimeter to check whether the AC voltage between the L line and N line is within the normal range.</p> <p>If the AC voltage is too high, check local supply voltages and contact the supplier if the voltage exceeds normal values.</p> <p>If the AC voltage is too low, ensure the AC cable is properly connected and that the insulation is not compressed into the AC terminal. Ensure a suitable sized cable was used to connect the mains supply.</p> <p>Make sure the grid voltage in your area is stable.</p>
4	PV Voltage Fault	The inverter has detected that the PV voltage is outside the normal range of the rated requirements.	<p>Turn off the PV switch and use a multimeter to check whether the open circuit voltage of the panel is below 600V.</p> <p>If the voltage is too high, reduce the number of connected panels to lower the input voltage.</p>
5	DCI High	The inverter has detected a high DC component in the AC output.	<p>Try restarting the inverter and check if the fault still exists.</p> <p>If the fault persists, contact after-sales service immediately.</p>
6	Current Leak High	A ground fault may be caused by improper AC side N-line connection or high humidity.	<p>Use a multimeter to check the voltage between the inverter and the grounded frame. The voltage should be close to 0V.</p> <p>If voltage is detected, check that the N wire and ground wire on the AC side are properly connected.</p> <p>If this failure occurs in the early morning, dawn, or rainy days, it may be due to temporary high humidity and should resolve on its own.</p>

TROUBLESHOOTING

No.	Fault Name	Reason of Fault	Handling Suggestions
7	PV Isolation	Possible poor grounding of photovoltaic panels, aging PV panels, damaged DC cables, or high humidity.	<p>Use a multimeter to check that the resistance between the inverter and the grounded frame is close to zero. If not, check the system wiring.</p> <p>If humidity is too high, isolation failure may occur temporarily.</p> <p>Check the resistance of PV1+/PV2+/BAT+/PV- to ground. If it is below 30kΩ, verify system wiring.</p> <p>Restart the inverter and check if the fault still exists. If the issue persists, contact after-sales service.</p>
8	No Utility	The inverter does not detect grid information.	<p>Use a multimeter to check whether there is voltage on the AC side.</p> <p>Ensure the grid voltage is normal.</p> <p>Check that the AC cable is firmly connected and not loose.</p> <p>If everything is fine, try disconnecting the AC circuit breaker and reconnecting it after 5 minutes.</p>
9	Bus Over Voltage	The internal BUS voltage is out of range	<p>Restart the inverter.</p> <p>If the fault still exists, contact after-sales service.</p>
10	DSP Communication Fault	Caused by strong external magnetic field interference	<p>Restart the inverter.</p> <p>If the fault persists, contact after-sales service.</p>
11	Hall Sensor Fault	HCT detection failure in the system	Contact after-sales service.
12	GFCI Fault	Abnormal Ground Fault Circuit Interrupter (GFCI) detection	Contact after-sales service.
13	Relay Fault	The neutral and ground wires on the AC side are not properly connected or are intermittently faulty	<p>Check with a multimeter whether the voltage between N and ground is below 10V.</p> <p>If voltage is higher, confirm that the N and ground wires are correctly connected.</p> <p>Restart the inverter if necessary.</p>

No.	Fault Name	Reason of Fault	Handling Suggestions
14	EEPROM Fault	Caused by external strong magnetic field interference	Restart the inverter. If unresolved, contact after-sales service.
15	Consistent Fault	The internal programs of the system do not match	Restart the inverter. If the fault persists, contact after-sales service.
16	ARM Communication Fault	Caused by strong external magnetic field interference	Restart the inverter. If the fault persists, contact after-sales service.
17	Back-Up Overload Fault	Total backup load exceeds the rated output power	Reduce the off-grid loads to keep total power below the rated output.
18	BMS Comm Fault	The inverter and lithium-ion battery communication is abnormal	Power off the inverter and check the BMS cable connection. If unresolved, contact after-sales service.
19	Bat Volt Low	Lithium battery voltage is below 196V Lead-acid battery voltage is below (LV- cell × 1V)	Confirm that the battery connection cable is securely attached. Ensure that the battery is switched on and the LED is lit. Check that the battery is not over-discharged. If it is, enable forced charging in the inverter settings to recover the battery after power replenishment.Or Use Activate Battery setting to wake and charge a very low battery. If the issue persists, contact the dealer or after-sales service.
20	Bus Unbalance Fault	The positive and negative Bus voltage difference exceeds 70V	Contact after-sales service.
21	Meter Comm Loss	The inverter is not communicating properly with the meter	Check that the meter and inverter are correctly connected. Ensure that the RX/TX communication lines are not reversed. Ensure you are using a single pair of wires, Belden RS485 cable is best.
22	Battery Need Charge	The battery voltage is too low to discharge	Charge the battery from the AC supply.

Remove Machine

Follow the shutdown procedure described in section “Disconnect the Inverter (Shutdown)” to disconnect the inverter completely.

Dismantling the inverter:

1. Ensure the inverter is fully disconnected and powered down.
2. Remove all connection cables from the inverter.
3. Unscrew and remove all projecting cable glands.
4. Remove batteries from the Inverter.
5. Carefully lift the inverter off its mounting bracket.
6. Unscrew and remove the bracket screws from the wall.



CAUTION - Ensure System is Fully Shut Down and Cool

- ✔ It is necessary to wait for more than 20 minutes after shutdown.
- ✔ This confirms that the machine is completely powered off and the surface temperature has cooled before you perform any other actions on the machine.

Scrap Machine (Disposal)

When the inverter can no longer be used and needs to be scrapped, please dispose of it according to the electrical waste disposal requirements of your country or region. You can contact your dealer or the customer service center for consultation and disposal.



NOTICE - Proper Disposal Required

- ✔ The hybrid inverter must not be disposed of with household waste.

GivEnergy

Phone	UK +44 01377 252 874 NL +31 85 208 6376
Email	UK support@givenergy.co.uk NL support@givenergy.com SA support.sa@givenergy.com AU martin.cobb@givenergy.com
Website	www.givenergy.com